

Solar Light's [PWA254](#), germicidal lamp monitor, is specifically designed to continuously monitor UV output from UVC lamps, in air or high pressure water disinfection tank (reactor), and can provide an indication of the effectiveness of the lamps as they age when used with a data acquisition system. This sensor is sensitive to the sterilizing UVC wavelengths of mercury lamps at 253.7nm.

PWA254 has a superior cosine performance, 20mm 1.5mm pitch exterior thread, and a Molex[®] style connector easy connection to the user interface. The sensor has a 0 – 5 V linear analog voltage output signal with a nominal scaling range of 1V ~ 100 μ W/cm². The circuit can be powered with a 9V battery, or other DC voltage source in the range 8 – 24 Vdc.

UV water and air disinfection systems are only as good as the effectiveness of the germicidal lamps. With time, even the best UV water treatment system will show a significant degradation in its ability to disinfect water. Germicidal lamp output decreases as the lamp ages and/or becomes dirty through use.

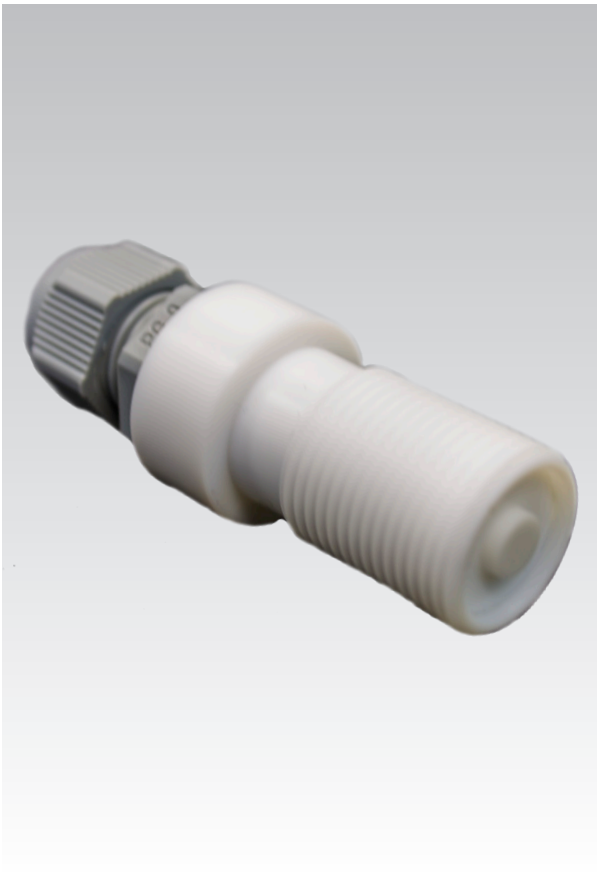

Applications

- Disinfection of Plant Effluent

Features and Benefits

- Multidirectional Measurement
- Excellent Cosine Response
- Teflon Casing
- High Sensitivity
- Adjustable Range and Sensitivity
- Resistant to Most Solvents
- Standard Thread for Easy Mounting

SPECIFICATIONS	
Output Signal	0-5 VDC, 3 Wire
Input Power	8-24 VDC @ 5mA
Sensitivity	5 V, 500 [$\mu\text{W}/\text{cm}^2$] or 10 [$\text{mV}/\mu\text{W}/\text{cm}^2$]
Sensitivity Uncertainty	$\pm 10\%$
Operating Environment	32 to 120°F (0 to +50°C) Splashproof
Cable Length	3ft (914mm) (Other lengths available)
Dimensions and Weight	*See outline drawing

Part Number: 210105

Revision Level: B

Specifications subject to change without notice.

PWA254 Germicidal Lamp Detector

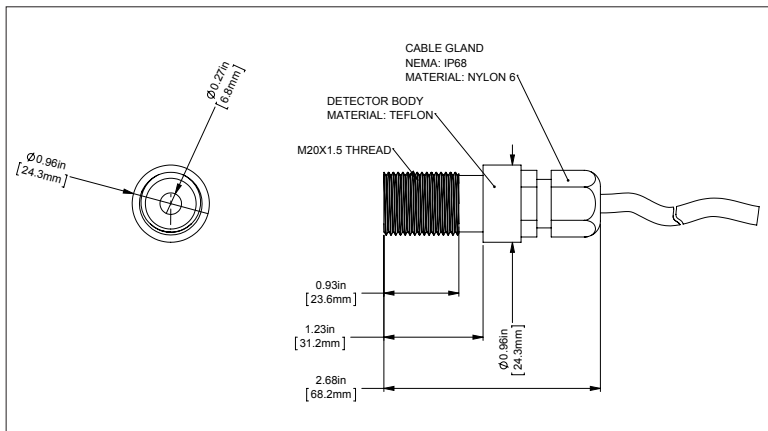

Est. Weight: 1.2 oz. (35g)

PWA254 Wire Connections

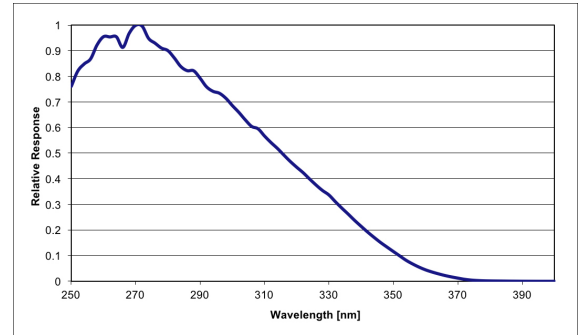
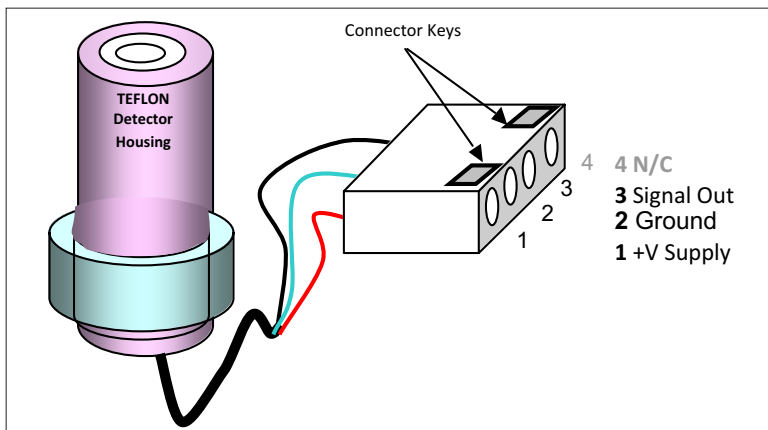

Fig. 1. Linear Spectral Response

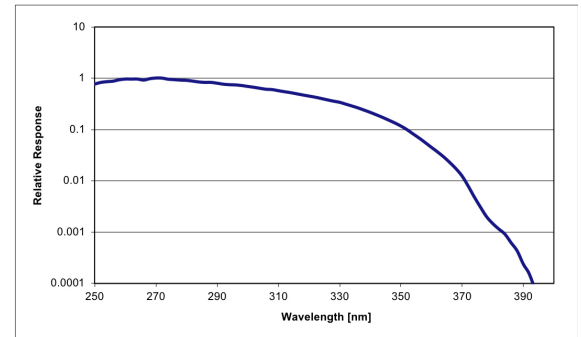

Fig. 2. Log Spectral Response

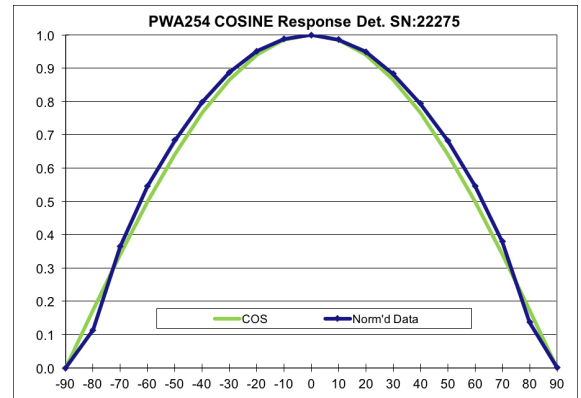

Fig. 3. Cosine Response

Since 1967, Solar Light Company, LLC has been recognized worldwide as America's premier manufacturer of Precision Solar Simulators and Light Sources, Light Measurement Instrumentation, UV Transmittance Analyzers, Meteorological Instrumentation, and Digital and Analog Sensors. Our advanced line of UV, visible, and IR radiometers and light meters measure laboratory, industrial, environmental, and health related light levels with NIST traceable accuracy. Column ozone, aerosol, and water vapor thickness measurements, in addition to long-term global ultraviolet radiation studies all over the world are performed using our atmospheric line of instrumentation. Solar Light also provides NIST traceable spectroradiometric analyses, calibrations for light meters and light sources, accelerated ultraviolet radiation degradation testing of materials, and OEM instrumentation and monitors. Please visit our website for more details, specifications, and pictures!



State Of The Art Solar Simulators available in 150-1000+ watt UV or AM variations for a variety of applications including PV Cell Testing, Materials Testing, Pre-Irradiation for In Vitro Broad Spectrum Sunscreen Testing, SPF Testing, and much more.



Multi-Functional Professional Grade Radiometers available with and without data logging, and compatible with over 130 Solar Light PMA-Series Sensors to measure UV, Visible and IR wavelengths. Specialty Meters also available to measure UV Radiation, SUV/UVA, Scotopic/Photopic Spectra, and much more.



Advanced NIST-Traceable Sensors for accurate measurement of UVA, UVB, UVA+B, UVC, Visible, IR, Photostability, Temperature, and Custom Wavelength – well over 130 models in both digital and analog configurations, all compatible with our Radiometers.



Ultraviolet Transmittance Analyzers available as complete integrated turnkey systems to meet the latest ISO24443 requirements.



Handheld Ozonometers and Sunphotometers for fast and dependable Column Ozone, Aerosol, and Water Vapor Thickness measurements, in addition to long-term global ultraviolet radiation studies.