

Solar Light's NIST-Traceable **Model PMA2140 Digital Visible and Infrared Global Radiometer** measures irradiance within the range of 400 to 1100nm, and is intended primarily for cost-sensitive applications where the flat spectral response of our thermopile-based pyranometers is not required. This sensor can be used to monitor the global solar irradiance (direct + diffuse.) It is factory calibrated to accurately read the global solar irradiance (from 300 to 2800nm) if exposed to the standard sun, even though the sensor is not sensitive beyond 1100nm. This is achieved by applying a correction factor during calibration. The angular response of the PMA2140 sensor is cosine corrected, and suitable for measurements of diffuse radiation or radiation from extended sources.



Applications

- Meteorology
- Agriculture
- Solar Power Research and Testing
- Heating and Air Conditioning
- Lighting
- Physics and Optical Laboratories

Features and Benefits

- Wide Spectral Range
- Excellent Long-Term Stability
- Cosine Corrected
- Calibration Traceable to World Radiometric Reference (WRR)
- High Sensitivity
- Low Cost
- Selectable Units





Standard Chassis - IP60
1.8" (45.8mm) High x 1.6" (40.6mm) Diameter



Weatherproof Standard Chassis - IP68
Can be submersed up to 3 meters deep
1.8" (45.8mm) High x 1.6" (40.6mm) Diameter

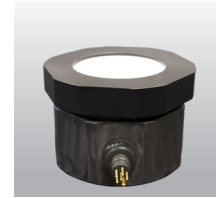

Waterproof Underwater Chassis - IP68
Can be submersed up to 100 meters deep
3.3" (83.4 mm) High x 4.7" (119.7 mm) Diameter

Options:

- Tripod Mounting Plate
- Weatherproof Chassis (submersible up to 3 meters)
- Waterproof Underwater Chassis (submersible up to 100 meters)
- Analog Model Also Available (Model PMA1140)

SPECIFICATIONS	
Spectral Response	400-1100nm, Figure 1
Cosine Response	±5% for Angles <30° (Standard Chassis)
Range	*See model chart on the next page
Display Resolution	*See model chart on the next page
Operating Environment	32 to 120°F (0 to +50°C)
Temperature Coefficient	Negligible
Cable Length	*See cable length chart below
Dimensions and Weight	*See outline drawings
REFERENCES	
"Solar Spectral Irradiance" Technical Report of the CIE, Publ No CIE 85	

Part Number: 210018

Revision Level: C

Specifications subject to change without notice.

CABLE LENGTHS	
Standard Chassis	6ft Straight Cable (1.82m) <i>(Custom Lengths Available)</i>
Weatherproof Chassis	15ft Standard Cable (4.57m) <i>(Custom Lengths Available)</i>
Waterproof Underwater Chassis	Cable Length by Request. Specify up to 100 Meters.

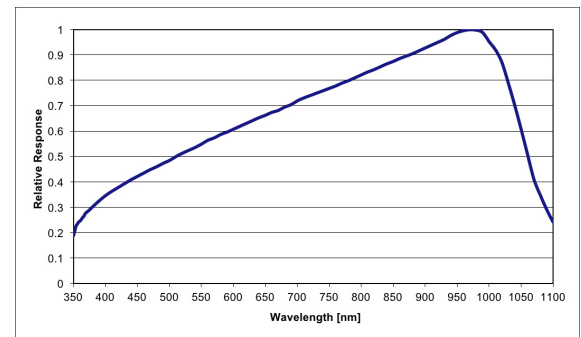

Fig. 1. Linear Spectral Response

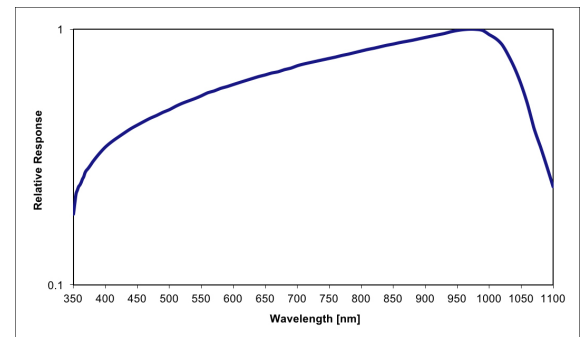

Fig. 2. Log Spectral Response

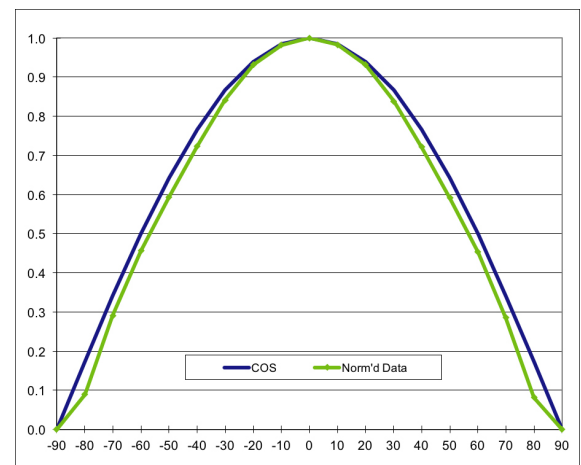

Fig. 3. Cosine Response

Partial Model Selection Chart



STANDARD CHASSIS - IP60		
Model	Range	Display Resolution
PMA2140L	2,000 [$\mu\text{W}/\text{cm}^2$]	0.01 [$\mu\text{W}/\text{cm}^2$]
PMA2140	200 [mW/cm^2] or 2,000 [W/m^2]	0.001 [mW/cm^2] or 0.01 [W/m^2]
PMA2140H	2,000 [mW/cm^2] or 20,000 [W/m^2]	0.01 [mW/cm^2] or 0.1 [W/m^2]



WEATHERPROOF CHASSIS - IP68		
Model	Range	Display Resolution
PMA2140L-WP	2,000 [$\mu\text{W}/\text{cm}^2$]	0.01 [$\mu\text{W}/\text{cm}^2$]
PMA2140-WP	200 [mW/cm^2] or 2,000 [W/m^2]	0.001 [mW/cm^2] or 0.01 [W/m^2]
PMA2140H-WP	2,000 [mW/cm^2] or 20,000 [W/m^2]	0.01 [mW/cm^2] or 0.1 [W/m^2]

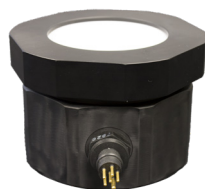

WATERPROOF UNDERWATER CHASSIS - IP68		
Model	Range	Display Resolution
PMA2140L-UW	2,000 [$\mu\text{W}/\text{cm}^2$]	0.01 [$\mu\text{W}/\text{cm}^2$]
PMA2140-UW	200 [mW/cm^2] or 2,000 [W/m^2]	0.001 [mW/cm^2] or 0.01 [W/m^2]
PMA2140H-UW	2,000 [mW/cm^2] or 20,000 [W/m^2]	0.01 [mW/cm^2] or 0.1 [W/m^2]

Custom ranges, cable lengths, and cable types are available upon request – please consult factory for details

Standard Chassis

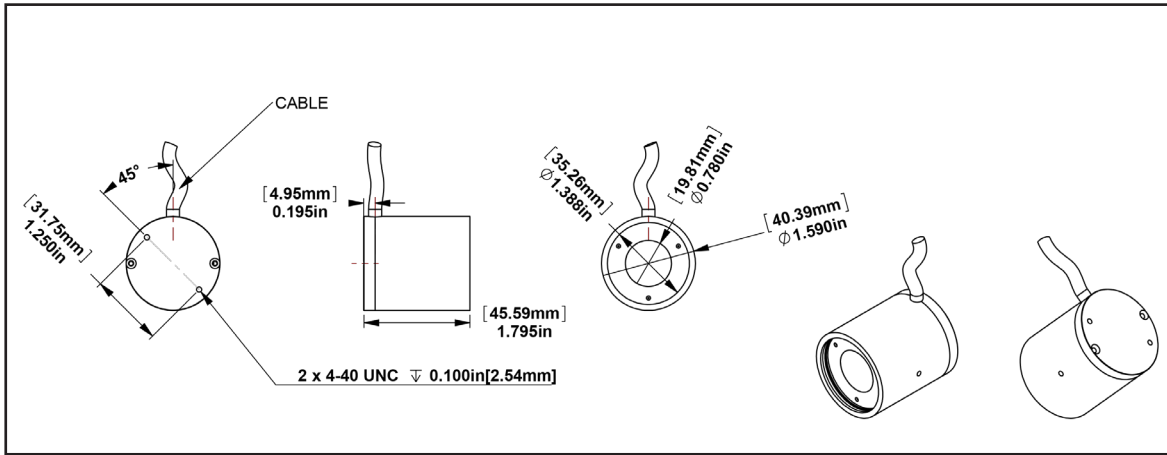

Est. Weight: 4 oz. (113 g)

Weatherproof Chassis

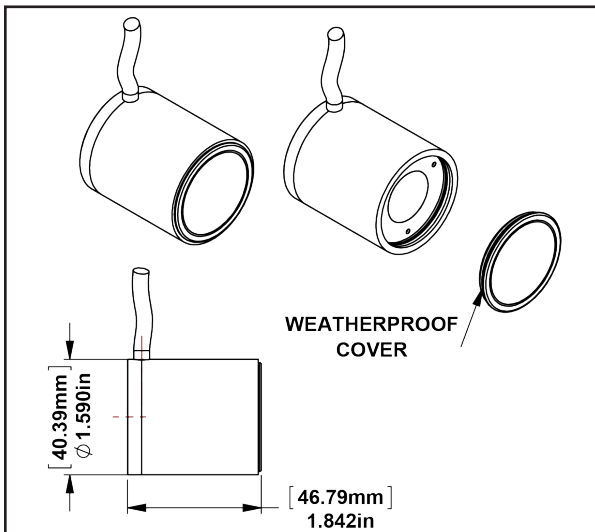

Est. Weight: 4.2 oz. (119 g)

Waterproof Underwater Chassis

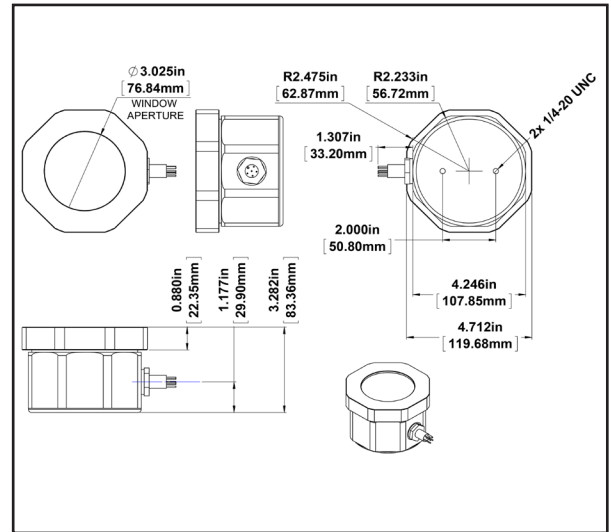

Est. Weight: 3.7 lbs. (1678 g)

Since 1967, Solar Light Company, LLC has been recognized worldwide as America's premier manufacturer of Precision Solar Simulators and Light Sources, Light Measurement Instrumentation, UV Transmittance Analyzers, Meteorological Instrumentation, and Digital and Analog Sensors. Our advanced line of UV, visible, and IR radiometers and light meters measure laboratory, industrial, environmental, and health related light levels with NIST traceable accuracy. Column ozone, aerosol, and water vapor thickness measurements, in addition to long-term global ultraviolet radiation studies all over the world are performed using our atmospheric line of instrumentation. Solar Light also provides NIST traceable spectroradiometric analyses, calibrations for light meters and light sources, accelerated ultraviolet radiation degradation testing of materials, and OEM instrumentation and monitors. Please visit our website for more details, specifications, and pictures!



State Of The Art Solar Simulators available in 150-1000+ watt UV or AM variations for a variety of applications including PV Cell Testing, Materials Testing, Pre-Irradiation for *In Vitro* Broad Spectrum Sunscreen Testing, SPF Testing, and much more.



Multi-Functional Professional Grade Radiometers available with and without data logging, and compatible with over 130 Solar Light PMA-Series Sensors to measure UV, Visible and IR wavelengths. Specialty Meters also available to measure UV Radiation, SUV/UVA, Scotopic/Photopic Spectra, and much more.



Advanced NIST-Traceable Sensors for accurate measurement of UVA, UVB, UVA+B, UVC, Visible, IR, Photostability, Temperature, and Custom Wavelength – well over 130 models in both digital and analog configurations, all compatible with our Radiometers.



Ultraviolet Transmittance Analyzers available as complete integrated turnkey systems to meet the latest ISO24443 requirements.



Handheld Ozonometers and Sunphotometers for fast and dependable Column Ozone, Aerosol, and Water Vapor Thickness measurements, in addition to long-term global ultraviolet radiation studies.