

USER MANUAL

MODEL 501-DA ANALOG UV BIOMETER SENSOR



Part Number: 210137
Revision Level: A

TABLE OF CONTENTS

1	INTRODUCTION.....	4
	1.1 About This Manual.....	4
	1.2 Key Features.....	4
	1.3 Technical Specifications.....	4
2	INSTALLATION.....	5
	2.1 Installing The Sensor.....	5
	2.2 Connecting The Sensor To Data Logger.....	5
3	MAINTENANCE.....	6
	3.1 Routine Maintenance.....	6
	3.2 Troubleshooting.....	6
4	DATA INTERPRETATION & CALIBRATION.....	7
5	PRINCIPLE OF OPERATION.....	8
6	APPENDICES.....	8
	6.1 Appendix A - Electrical Interface.....	8
	6.2 Appendix B - Erythema Action Spectrum.....	9
7	REFERENCES.....	9

1 INTRODUCTION

The Model 501A UV-Biometer™ is the continuation of the line of Robertson- Berger Weatherproof meters that have been employed in the worldwide network for UV-B monitoring. The UV-Biometer was designed by D. Berger and M. Morys, based on the experience gained during the Robertson-Berger meter design (Berger 1976) and on research focused on the temperature dependency and stabilization of the Robertson-Berger UV-B sensor (Blumthaler, Ambach, Morys, Slonika 1989).

1.1 ABOUT THIS MANUAL

This manual has been designed for a variety of user needs. The manual contains the following sections:

- Introduction
- Installation
- Maintenance
- Data Interpretation & Calibration
- Principles of operation
- Appendices

These sections provide logical sections of the information needed to get the most from the 501A UV-Biometer. They cover aspects related to UV-Biometer usage, beginning from basic installation procedure and ending on some examples of calculations and interpretation of measured quantities.

This special sign emphasizes the warnings, helpful hints and other important information that will help you get better use from the UV-Biometer.

1.2 KEY FEATURES

- Compact, Light-Weight Sensor
- Spectral Response Close to Erythema and Other Spectra
- Temperature Stabilization of the Phosphor
- Analog Output for UV Signal & Sensor Temperature
- Battery Operation

1.3 TECHNICAL SPECIFICATIONS

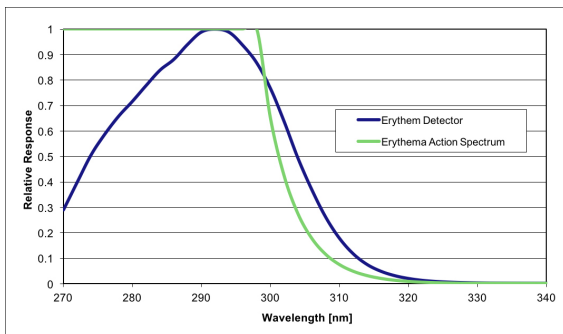

Figure 1 Linear Spectral Response

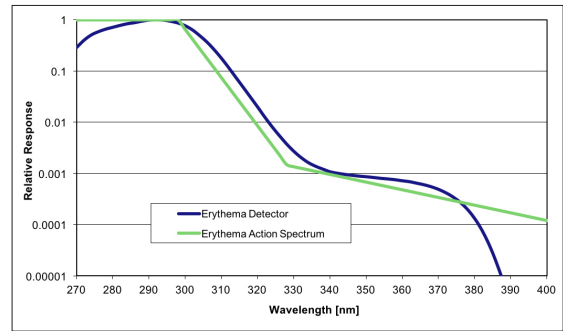

Figure 2 Log Spectral Response

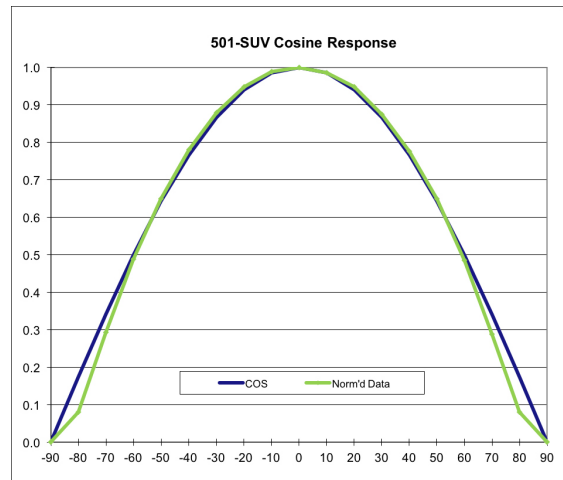

Figure 3 Cosine Response

SPECIFICATIONS	
Spectral Range Based on Erythema Action Spectrum	280-320nm - 99.503% 320-400nm - 0.497%
Measurement Range	0-10 [MED/hr]
Angular Response	Within 5% of Ideal Cosine
Response Time	1 Second (0.1 second on demand)
Temperature Correction	1% per C
Expected Daily Uncertainty	+/-5%
Operating Conditions	-40 to 120°F (-40 to 50°C)
Dimensions (HxDiam)	5.5" x 5.9" (14 x 15 cm)
Weight	2 lbs (0.9 kg) (without cable)
Cable	50 ft (15.24 m) Cable with Hermetic Connector Standard. Up to 200 ft (61 m) Length Optional
Mounting	3 Leveling Feet, Circular Level
Sensor Signal Output	0-2.5V, 0.25[V/(MED/hr)], 0.5mA/hr
Sensor Temperature Output	0-1V, 1V=25 C, Sensitivity 20mV/ C, 0.5mA max
Power Requirements	5.5-25V/5mA Max for Signal Circuit. 11-15V/1A Max for Temp Stability

2 INSTALLATION

Proper installation of the sensor and correct connection to the data logger assures accurate measurement of the UV-B radiation.

2.1 INSTALLING THE SENSOR

To obtain correct readings, placement of the sensor must meet the following criteria:

- As much of the whole sky as possible should be visible from the sensor location. Diffused radiation from the entire sky contributes significantly to the UV-B.
- Dust or smoke from vents or chimneys may cause substantial change of the UV-B radiation reaching the sensor.
- The sensor shouldn't be located in places where snow or water tends to accumulate.
- Locating the sensor together with equipment that needs frequent service may result in incorrect dose measurement since it will be disturbed by personnel blocking the light.
- A lightning rod should be installed within 2 to 4 meters if the sensor is exposed on the top of a high building or in an area where thunderstorms are frequently observed.

A sensor base is provided to hold the sensor in its selected place. The construction of the base allows leveling the sensor after it is mounted. The bottom plate of the base has 3 countersunk holes to fasten the base using flathead wood-screws. After the base is fastened, align the top plate with the bottom plate. Insert the tripod legs into the three openings and rotate the top plate clockwise and lock the sensor by rotating the handle left or right.

After the sensor is mounted, plug in the weatherproof cable connector and slide the rubber boot over the connect. Level the sensor, if necessary. The sensor cable should be protected against damage.

2.2 CONNECTING THE SENSOR TO A DATA LOGGER

Typical connection between the sensor and data acquisition system is shown in Figure 4. The connector pin numbers and the wire colors of the supplied cable are shown. The use of differential inputs is strongly recommended. This way the possibility of ground loops and crosstalk from power distribution system is eliminated and best system performance achieved. More detailed description of the sensor interface is provided in Appendix A.

UV signal should be connected to an input configured for 0...+2.5V. The sensitivity of the calibrated sensor is approx. 0.25 [V/(MED/hr)] (it is an equivalent of 4 [(MED/hr)/V]). The sensitivity is adjusted to 0.25 [V/(MED/hr)] during the initial calibration of the sensor. It is recommended not to change the original settings during consecutive calibrations but rather calculate new sensitivity. The new value will be given for each sensor on the calibration certificate. This way the record of the sensor sensitivity will be a good indication of the instrument as well as the calibration procedure longterm stability.

The sensitivity coefficient can be entered to the data logger to directly convert the voltage to erythemal effectiveness in [MED/hr].

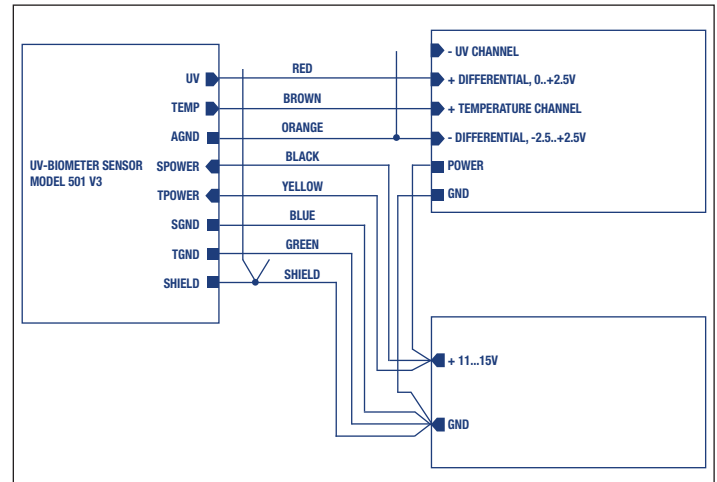

Figure 4 Typical Connection to Data Logger

The temperature signal may be negative when the sensor temperature is below -25°C. If such temperature is expected the temperature signal should be connected to an input configured for -2.5... +2.5V. The temperature sensor is calibrated at 25°C and the output voltage at this temperature is + 1.0V. The sensitivity is 20mV/°C. Thus the temperature can be calculated from the formula:

$$T = 50 \times U_{TEMP} - 25 \text{ (}^\circ\text{C)}$$

where U_{TEMP} is the temperature output in Volts.

The UV sensor has the temperature coefficient of approx 1%/°C. The temperature coefficient varies with the spectrum of the measured light. For the ozone column between 2.7 and 3.3mm and solar zenith angle changing from 0° to 70° the temperature coefficient can vary between 0.9 and 1.4%/°C. The highest temperature coefficient is observed for the low sun. By stabilizing the sensor temperature at a constant value of 25°C the temperature effect is eliminated and long term stability as well as lifetime of the sensor are improved.

In applications where no power is available for the temperature controller or slightly degraded accuracy is acceptable the temperature compensation algorithm may be employed. By applying the temperature correction of 1%/°C most of the daily dose will be collected with the temperature effect virtually eliminated. The temperature corrected sun burning effectiveness can be calculated according to the formula:

$$SUV_{corr} = \frac{SUV_{meas}}{1 + (T_{det} - 25) \times 0.01}$$

where SUV_{meas} is the SUV value measured by the sensor and T_{det} is the actual sensor temperature in °C. If possible, the temperature correction algorithm should be programmed into the data logger and applied for every sample before integration of the dose. Another approach is to calculate an average temperature for the integration period and then correct the integrated dose. However, accuracy may be slightly degraded if fast temperature change occurred during the integration period with simultaneous UV intensity change.

The temperature correction can be also used along with temperature stabilization to compensate small temperature variations of the sensor and complement the stabilization when the ambient temperature is above or below the heating/cooling abilities of the controller.

The temperature controller can draw 1Amp peak current and the power supply must be able to handle those requirements. The average power consumption depends on the ambient temperature and insulation and is usually only a fraction of peak value. To save energy the temperature controller can be turned off during the night by simply disconnecting the power (**TPOWER**). This power cycling can be done by the use of

mechanical or solid state relay controlled by the data logger output. The time or actual UV intensity can be used as criteria to determine whether the temperature controller can be turned off or not. However, if the power consumption is not an important aspect, it is recommended to keep the sensor temperature constant all the time.

The temperature controller is electrically insulated from signal circuitry inside the sensor. If the power distribution system is connected properly it eliminates the possibility of crosstalk from power consuming circuit. As shown in Figure 4 the power supplying wires should be connected together at one point at the power supply terminals, and long ground wires common for 2 or more devices should be avoided especially if any of those devices is connected to a single ended input of the data logger. The wire resistance must be also taken into consideration if long cables are used. For example 50 ft of 22AWG cable will result in 1.6 ohm resistance. To assure the minimum voltage of 11 volts for the temperature controller the power supply should have an output of at least 12.6 volts. However, the temperature controller will also work with lower supply voltage but the cooling and heating abilities will be degraded.

3 MAINTENANCE

3.1 ROUTINE MAINTENANCE

Some minimal maintenance is required to assure accurate data from the sensor. The following maintenance schedule is recommended, but some changes may be necessary depending on the operating environment and other limitations.

FREQUENCY	OPERATION
Daily / Weekly	Cleaning of the dome, examination of the recorded data quality
Monthly / Bimonthly	Examination of the moisture indicator, sensor mounting and leveling
Yearly	Re-calibration & maintenance by manufacturer, installation (wiring) checkup

Snow, frost, drops of water or dirt on the dome may change the sensor reading significantly therefore dome cleaning is very important. Commercially available blowers can be used to keep the dome surface clean and reduce the maintenance needs. The data recorded by the data logger should be also checked as often as possible. It assures that any malfunction of the sensor or data logger will be spotted early.

When the moisture indicator is pink in color the desiccant in the moisture indicator plug needs to have the moisture removed or the plug replaced. To remove the moisture from the indicator plug place it in an oven at a low temperature (~250°F) for 2 hours or until the indicator has changed from pink back to blue. If vacuum equipment is available vacuum the air out of the sensor via the tank valve and

add dry nitrogen back into the sensor not exceeding 3 pounds of pressure. **Do not exceed 3 pounds of pressure or damage to the sensor will result.**

3.2 TROUBLESHOOTING

In this chapter, some problems that can be faced when using the 501A UV-Biometer are described. If there are any malfunction symptoms, good practice is to check that:

- All cables are correctly plugged in
- The power is properly supplied
- The sensor is installed properly

The sensor together with data logging system and usually with other devices connected to it may compose a quite complicated system. Finding the cause of the malfunction in such a system may not be easy.

Some specific problems are described below and possible reasons are indicated:

- There is no signal from the sensor:
 - No power supplied to the sensor
 - The data logger input may not function: check the signal from the sensor by connecting a voltmeter to the end of sensor cable (*usually mounted to terminal board*)
 - Broken cable: use ohmmeter to check the continuity of all wires in the cable

- The zero level of the UV signal is not stable or signal is noisy:
 - Moisture inside the sensor: the desiccator plug in the sensor should be checked
 - Corroded connections to the data logger, or connections exposed to moisture, excessive EMI
 - Crosstalk from other devices connected to the same data logger, excessive voltage connected to any input of the data logger
 - Intermittency in the power supply
- The temperature controller does not work:
 - There is no power supplied for the temperature controller
 - Broken wire in the sensor cable
- The temperature controller is not able to maintain the nominal sensor temperature of 25°C:
 - The ambient temperature is too high or too low relative to the thermostating temperature (*see technical specifications*)
 - The voltage supplied for temperature controller is lower than 11V
 - The connection of the wires supplying power is loose or corroded adding series resistance and reducing voltage receiving by the sensor

4 DATA INTERPRETATION & CALIBRATION

The biological effectiveness of the UV irradiation is measured in MED/hr (Minimum Erythema Dose per Hour). One MED/hr would cause minimal redness on type II skin after a one hour irradiation. The integral of the cross-multiplication of irradiating flux [W/cm²mn] and the Erythema Action Spectrum (McKinlay and Diffey 1987, see Appendix B) gives the Effective Power. It was established (Parrish 1982) that:

$$1 \text{ [MED/hr]} = 5.83 \cdot 10^{-6} \text{ [W/cm}^2\text{]} \text{ of Effective Power for a MED of } 21 \text{ mJ/cm}^2 \text{ effective dose.}$$

The Biologically Effective Dose is measured by integrating the Biologically Effective Power over a specified period of time. For example, irradiating the skin by a source having 2 [MED/hr] output for 30 minutes will result in 1 MED.

The Erythema Action Spectrum is only one of many action spectra observed in nature, with similar slope and wavelength range. Thus, the UV-Biometer can indicate the effectiveness of solar radiation for the induction of sunburn, phytoplankton mortality, skin elastosis and thymine dimers among other effects. Also, the UV-Biometer can be used for global UV monitoring, especially in conjunction with information about ozone thickness, cloud cover and air pollution.

The 501A UV-Biometer is initially calibrated by the manufacturer, to show the biological effectiveness of the solar radiation, according to the McKinlay-Diffey Erythema Action Spectrum and a 21 mJ/cm² to induce minimal skin redness. The sensor is calibrated for a clear sky, 30° solar zenith angle, 2.7 mm ozone column thickness, at sea level and at a 25°C temperature of the sensor.

Figure 5 shows the differences between the measured and calculated values for different ozone thicknesses and solar zenith angles. A

computer model is used to calculate the UV radiation reaching the Earth level (Green, 1979). The results can vary with measurement conditions, but it shows the order of magnitude of errors that can be expected. More important is to maintain the repeatability between units, and the spectral response of the sensor is strictly controlled over the entire technological process. Figure 1 shows also the allowed variation of the sensors responses. For the two extreme responses, the differences between readings should be within 6% for ozone thickness from 2.7 to 3.3 mm, and solar zenith angles 0° to 70°C.

The UV-Biometer should be periodically re-calibrated. The recommended period is one year. The calibration can be performed by the manufacturer or by transfer from a reference sensor that can be ordered for that purpose. The reference sensor should be connected to that same data logging system and the recordings from several days should be compared. The temperature stabilization should be turned ON for both sensors. Then, the data from both sensors can be loaded into the computer and compared using general purpose data processing software. The regression method is a very convenient way to find the difference between sensitivities of both sensors. The new sensitivity should be entered into the data logger.

The calibration by transfer is less accurate and introduces additional error due to different conditions in which the calibration is performed (solar angle, ozone, cloud cover etc.). Therefore the calibration performed by manufacturer is recommended. The calibration procedure assures independence on the factors mentioned above and traceability to radiation standards. When calibrated by manufacturer the desiccator plug is also changed.

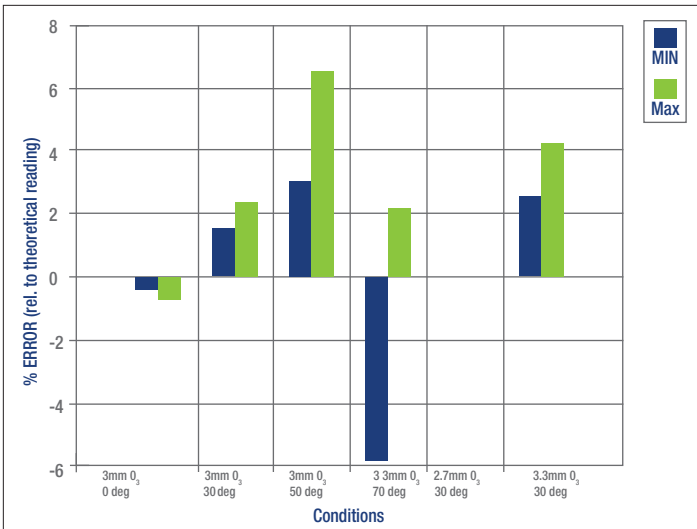

Figure 5 The measurement error due to spectral response variation

5 PRINCIPLE OF OPERATION

The principle of UV radiation measurement used in the 501A UV-Biometer is the same as that used for the Robertson-Berger meter. The solar light enters the sensor through the quartz dome and input filter. Then the partially filtered light, containing the whole UV spectrum, excites the phosphor. The visible light emitted by the phosphor which is detected by the photodiode. The photodiode and the phosphor are encapsulated in the

metal enclosure which is temperature controlled by the peltier element thermocouple. The current produced by the photodiode is converted to voltage and amplified. The temperature of the sensor is also converted to voltage. The military and industrial grade components selected assure stable operation over a wide range of conditions.

6 APPENDICES

6.1 APPENDIX A - ELECTRICAL INTERFACE

PLUG PIN	SIGNAL DESCRIPTION	SIGNAL NAME	WIRE COLOR
1	+5.5...25V/5mA; power for signal circuitry; protected against reverse polarity and overvoltage up to 50V.	SPOWER	Black
2	Power ground for signal circuitry: 5mA connected to analog ground and to the sensor case.	SGND	Blue
3	Power ground for temperature controller: 1A, electrically insulated from signal circuitry and sensor case.	TGND	Green
4	+11...15V, <1A @11V, current drops with voltage increase; power for temperature controller; not protected against reverse polarity.	TPOWER	Yellow
5	Analog ground to be connected to inverted inputs of the datalogger; connected to power ground for signal circuitry and the sensor case inside the sensor; electrically insulated from the temperature controller.	AGND	Orange
6	UV signal 0..+2.5V/0.5mA max; 0.25 [V/(MED/hr)] sensitivity; short circuit protected; should be connected to non-inverting input of the sensor.	UV	Red
7	Sensor temperature signal -0.5..+2.5V/ 0.5mA max; +1V output corresponds to 25°C, 20mV/°C sensitivity; short circuit protected; should be connected to the non-inverting input of the data logger.	TEMP	Brown
Shield	Protective ground; connected to the sensor case and thus to analog ground and power ground for the signal circuitry.	SHIELD	

6.2 APPENDIX B - ERYTHEMA ACTION SPECTRUM

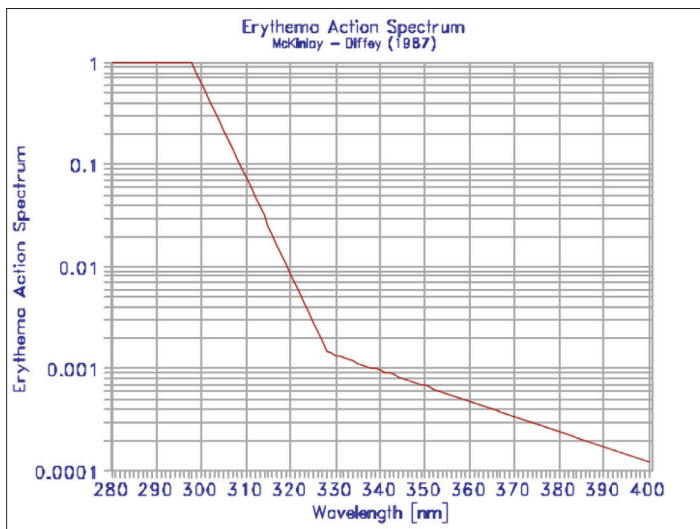

Figure 6 Erythema Action Spectrum (McKinlay and Diffey 1987).

7 REFERENCES

- Berger, D., (1976) The sun burning ultraviolet meter: design and performance. In *Photochem. Photobiol.* 24, 58 7-593.
- Blumthaler, M., W. Ambach (1986) Messungen der Temperaturkoeffizienten des RobertsonBerger Sunburn Meters und des Eppley UV-radiometers. In *Arch. Met. Geophys. BiocL, Ser. B*, 36, 357-363.
- Blumthaler, M., W. Ambach, M. Morys, J. Slomka (1989) Comparison of Robertson- Berger UV Meters From Innsbruck and Beisk. In *Publs. Inst. Geophys. Pol. Acad. Sc., D-32 (230)*, Warsaw.
- McKinlay, A. and B.L.Diffey (1987) A reference action spectrum for ultra-violet induced erythema in human skin. In *Human Exposure to Ultraviolet Radiation: Risks and Regulations* (Edited by W.F. Passchier and B.F.M. Bosnjakovic), pp 83-87. Elsevier, Amsterdam.