

Solar Light's **Model PMA1122 Analog Germicidal UVC Sensor** provides fast and accurate irradiance measurements of the effective germicidal radiation. Several packages are available for different types of environments, including standard, low profile, weatherproof, waterproof, and high volume / OEM chassis. Ultraviolet radiation at 253.7nm has been used in germicidal applications for several decades. Microorganisms in air and water can be killed using UV or a combination of UV and ozone. The UVC-producing germicidal lamps in purification systems must be continually monitored to ensure that the bacteria are receiving a lethal dose of radiation. When properly monitored, these expensive lamps can be utilized to their maximum useful life before replacement. The PMA1122 sensors can also be used to ensure that replacement lamps are performing to specification.



Applications

- Water Treatment Plants
- Purification Systems
- Environmental Testing

Features and Benefits

- High Sensitivity
- Cosine Corrected
- NIST Traceable Calibration
- CE Compliant





Standard Chassis - IP60
1.8" (45.8mm) High x 1.6" (40.6mm) Diameter



Weatherproof Standard Chassis - IP68
Can be submersed up to 3 meters deep
1.8" (45.8mm) High x 1.6" (40.6mm) Diameter

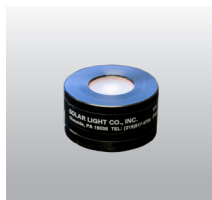

Low Profile Chassis - IP60
0.8" (21mm) High x 1.6" (40.6mm) Diameter



Waterproof Underwater Housing - IP68
Can be submersed up to 100 meters deep
3.3" (83.4 mm) High x 4.7" (119.7 mm) Diameter



OEM Chassis - IP60
1.6" (40.6mm) High x 1.3" (32mm) Diameter

Options:

- Tripod Mounting Plate
- Weatherproof Chassis (submersible up to 3 meters)
- Low Profile Chassis
- Waterproof Underwater Housing (submersible up to 100 meters)
- OEM Chassis for High Quantity Applications
- Digital Model for Interface with PMA Series Meters (Model PMA2122)

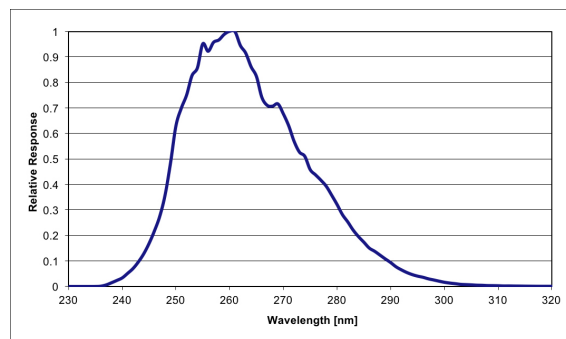

Fig. 1. Linear Spectral Response

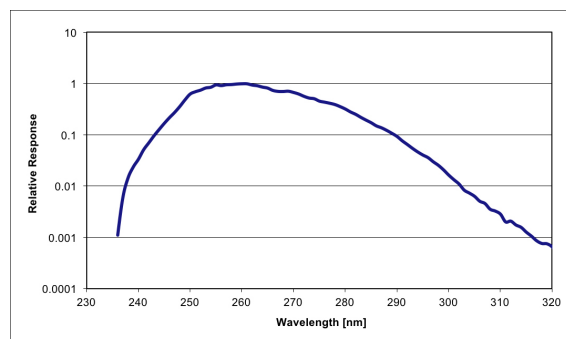

Fig. 2. Log Spectral Response

SPECIFICATIONS	
Spectral Response	249-259nm, Figure 1
Output Signal/Range	*See model chart on the next page
Input Power	*See model chart on the next page
Operating Environment	32 to 120°F (0 to +50°C)
Temperature Coefficient	Negligible
Cable Length	*See model chart on the next page
Dimensions and Weight	*See outline drawings
REFERENCES	
Nichodemus F., "Self study manual on optical radiation measurements", NBS Technical Note 910-1 (1976)	

Part Number: 210034

Revision Level: C

Specifications subject to change without notice.

Partial Model Selection Chart



STANDARD CHASSIS - IP60				
Model	Input Power	Output Signal	Range	Cable Type
PMA1122-S-05-2000	9-24 VDC @ 30 mA	0-5 VDC	2,000 [μ W/cm ²] or 2 [mW/cm ²]	Pigtail w/ 2 meter detachable cable
PMA1122-S-420-2000	9-24 VDC @ 70 mA	4-20 mA	2,000 [μ W/cm ²] or 2 [mW/cm ²]	Pigtail w/ 2 meter detachable cable
PMA1122	\pm 5-12 VDC @ <1 mA	*0-5 VDC	2,000 [μ W/cm ²] or 2 [mW/cm ²]	6' cable stripped/tinned
PMA1122G	\pm 5-12 VDC @ <1 mA	*0-5 VDC	20 [mW/cm ²] or 20,000 [μ W/cm ²]	6' cable stripped/tinned



WEATHERPROOF CHASSIS - IP68				
Model	Input Power	Output Signal	Range	Cable Type
PMA1122-WP-05-2000	9-24 VDC @ 30 mA	0-5 VDC	2,000 [μ W/cm ²] or 2 [mW/cm ²]	Pigtail w/ 2 meter detachable cable
PMA1122-WP-420-2000	9-24 VDC @ 70 mA	4-20 mA	2,000 [μ W/cm ²] or 2 [mW/cm ²]	Pigtail w/ 2 meter detachable cable
PMA1122-WP	\pm 5-12 VDC @ <1 mA	*0-5 VDC	2,000 [μ W/cm ²] or 2 [mW/cm ²]	15' cable stripped/tinned
PMA1122G-WP	\pm 5-12 VDC @ <1 mA	*0-5 VDC	20 [mW/cm ²] or 20,000 [μ W/cm ²]	15' cable stripped/tinned

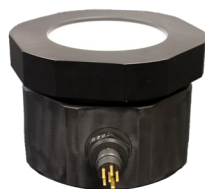

WATERPROOF UNDERWATER CHASSIS - IP68				
Model	Input Power	Output Signal	Range	Cable Type
PMA1122-UW-05-2000	9-24 VDC @ 30 mA	0-5 VDC	2,000 [μ W/cm ²] or 2 [mW/cm ²]	Customer to define length required
PMA1122-UW-420-2000	9-24 VDC @ 70 mA	4-20 mA	2,000 [μ W/cm ²] or 2 [mW/cm ²]	Customer to define length required



LOW PROFILE CHASSIS - IP60				
Model	Input Power	Output Signal	Range	Cable Type
PMA1122-F-05-2000	9-24 VDC @ 30 mA	0-5 VDC	2,000 [μ W/cm ²] or 2 [mW/cm ²]	Pigtail w/ 2 meter detachable cable
PMA1122-F-420-2000	9-24 VDC @ 70 mA	4-20 mA	2,000 [μ W/cm ²] or 2 [mW/cm ²]	Pigtail w/ 2 meter detachable cable
PMA1122-F	\pm 5-12 VDC @ <1 mA	*0-5 VDC	2,000 [μ W/cm ²] or 2 [mW/cm ²]	6' cable stripped/tinned
PMA1122G-F	\pm 5-12 VDC @ <1 mA	*0-5 VDC	20 [mW/cm ²] or 20,000 [μ W/cm ²]	6' cable stripped/tinned

*0 to Supply -0.5 Volts

Custom ranges, cable lengths, and cable types are available upon request – please consult factory for details

Partial Model Selection Chart



OEM CHASSIS - IP60				
Model	Input Power	Output Signal	Range	Cable Type
PMA1122-005-05-2000	9-24 VDC @ 30 mA	0-5 VDC	2,000 [μ W/cm ²] or 2 [mW/cm ²]	Bulkhead w/ 2 meter detachable cable
PMA1122-006-420-2000	9-24 VDC @ 70 mA	4-20 mA	2,000 [μ W/cm ²] or 2 [mW/cm ²]	Bulkhead w/ 2 meter detachable cable

***0 to Supply -0.5 Volts**

Custom ranges, cable lengths, and cable types are available upon request – please consult factory for details

Analog Wiring Chart

WIRE COLOR	PMA11xx-420	PMA11xx-05	PMA11xx
White	Power Ground*	Signal Out 0-5 VDC	Signal Out 0 to Vin-0.5 VDC
Blue		Power Ground	Power Ground
Green			Analog Ground
Red			Vin +5-12 VDC
Orange			Vin -5-12 VDC
Yellow			Signal Out 0 to Vin-0.5 VDC
Black		Analog Ground	
Pink		Vin 9-24 VDC	
Brown	Vin 9-24 VDC*		
Bare or Braid		Shield	Shield
A/C Plug			

*Current meter is connected in series with power supply and sensor

Standard Chassis

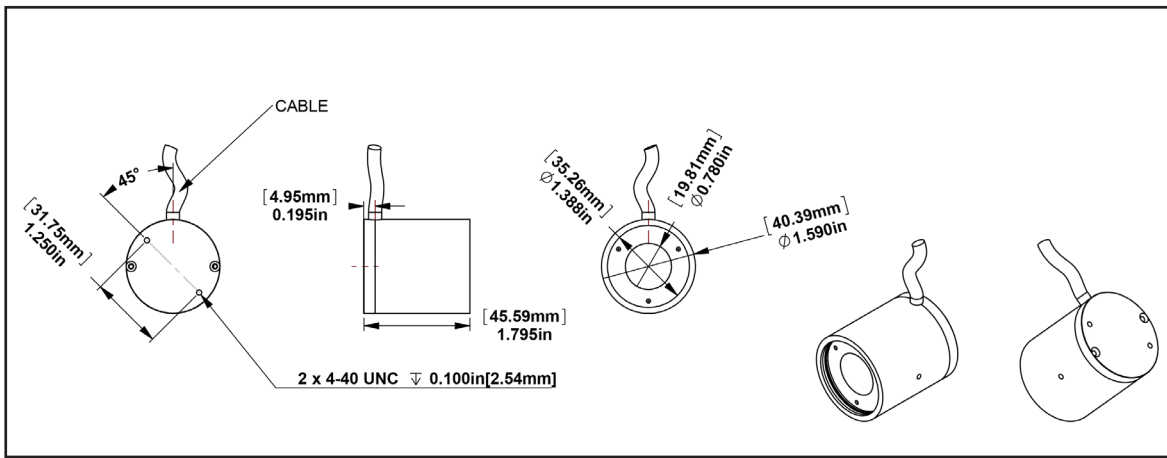

Est. Weight: 4 oz. (113 g)

Weatherproof Chassis

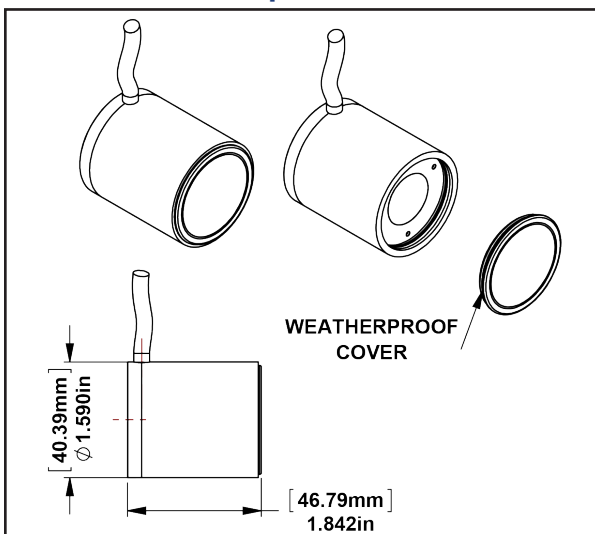

Est. Weight: 4.2 oz. (119 g)

Low Profile Chassis

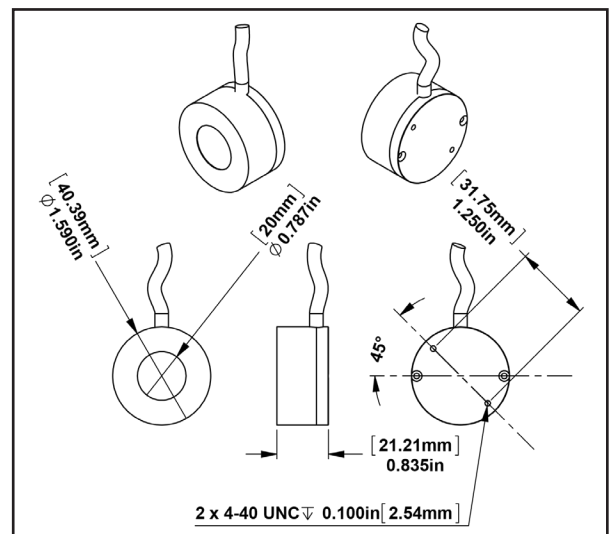

Est. Weight: 2.2 oz. (62 g)

Waterproof Underwater Housing

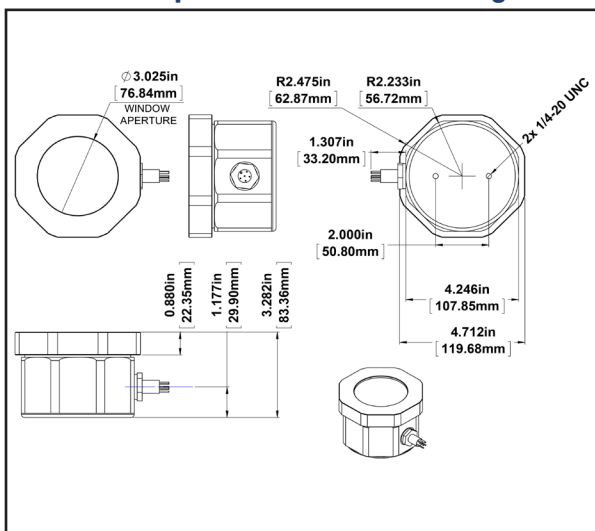

Est. Weight: 3.7 lbs. (1678 g)

OEM Chassis

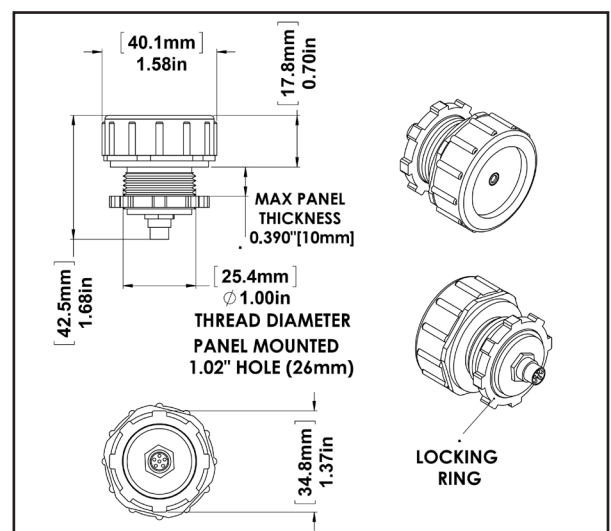

Est. Weight: 1.2 oz. (34 g)

Since 1967, Solar Light Company, LLC has been recognized worldwide as America's premier manufacturer of Precision Solar Simulators and Light Sources, Light Measurement Instrumentation, UV Transmittance Analyzers, Meteorological Instrumentation, and Digital and Analog Sensors. Our advanced line of UV, visible, and IR radiometers and light meters measure laboratory, industrial, environmental, and health related light levels with NIST traceable accuracy. Column ozone, aerosol, and water vapor thickness measurements, in addition to long-term global ultraviolet radiation studies all over the world are performed using our atmospheric line of instrumentation. Solar Light also provides NIST traceable spectroradiometric analyses, calibrations for light meters and light sources, accelerated ultraviolet radiation degradation testing of materials, and OEM instrumentation and monitors. Please visit our website for more details, specifications, and pictures!



State Of The Art Solar Simulators available in 150-1000+ watt UV or AM variations for a variety of applications including PV Cell Testing, Materials Testing, Pre-Irradiation for *In Vitro* Broad Spectrum Sunscreen Testing, SPF Testing, and much more.



Multi-Functional Professional Grade Radiometers available with and without data logging, and compatible with over 130 Solar Light PMA-Series Sensors to measure UV, Visible and IR wavelengths. Specialty Meters also available to measure UV Radiation, SUV/UVA, Scotopic/Photopic Spectra, and much more.



Advanced NIST-Traceable Sensors for accurate measurement of UVA, UVB, UVA+B, UVC, Visible, IR, Photostability, Temperature, and Custom Wavelength – well over 130 models in both digital and analog configurations, all compatible with our Radiometers.



Ultraviolet Transmittance Analyzers available as complete integrated turnkey systems to meet the latest ISO24443 requirements.



Handheld Ozonometers and Sunphotometers for fast and dependable Column Ozone, Aerosol, and Water Vapor Thickness measurements, in addition to long-term global ultraviolet radiation studies.