

Solar Light Company, LLC offers ISO-classified **Class II pyranometers** that measure global hemispherical radiation from 300 to 2800 nm. They utilize thermopile technology, assuring very broad spectral sensitivity, exceptional flatness, and excellent good long term stability.

These pyranometers feature a sixty-four thermocouple junction sensing element. The sensing element is coated with a highly stable carbon-based non-organic layer, which delivers excellent spectral absorption characteristics. The sensing element is housed under a single glass dome. The precision optical glass dome acts as a filter, with spectral bandpass that permits the full solar spectrum to pass through to the sensor. The glass dome also protects the sensor from the elements. The sensor is a high quality blackened thermopile. Heating of the sensor by incoming solar radiation produces a signal in the  $\mu$ volt range. Each pyranometer has its own calibration factor.

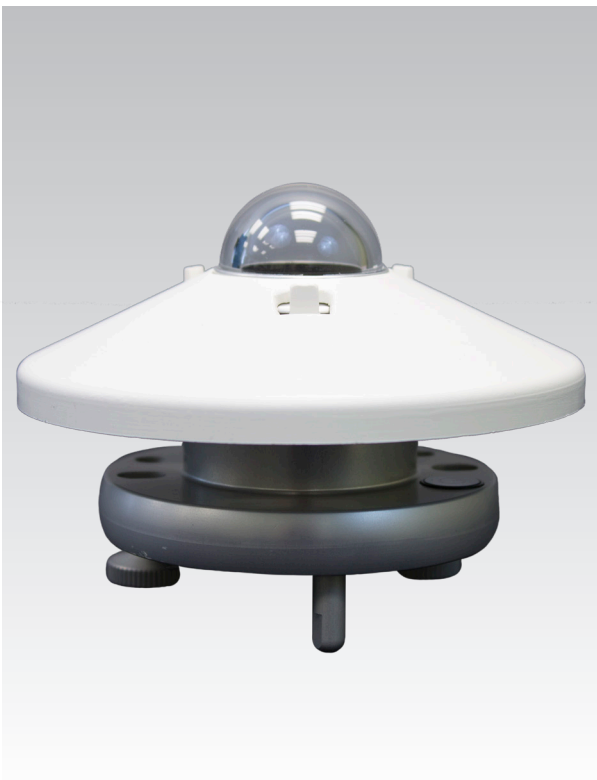

### Applications

- Meteorology
- Agriculture
- Solar Power Research and Testing
- Heating and Air Conditioning
- Lighting
- Physics and Optical Laboratories

### Features and Benefits

- Very Wide and Flat Spectral Response
- Excellent Long-Term Stability
- Cosine Corrected
- Calibration Traceable to World Radiometric Reference (WRR)
- ISO Classified
- Low Cost
- Weatherproof

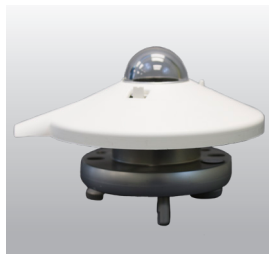
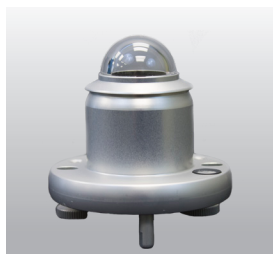

SPECIFICATIONS		
<b>Spectral Response</b>	300-2800nm, Figure 1	
<b>Range</b>	2000 [W/m <sup>2</sup> ] or 200 [mW/cm <sup>2</sup> ]	
<b>Display Resolution</b>	1 [W/m <sup>2</sup> ] or 0.1 [mW/cm <sup>2</sup> ]	
<b>Operating Environment</b>	-40 to 175°F (-40 to +80°C)	
<b>Temperature Coefficient</b>	<5% (-10 to +40°C)	
<b>Cable Length</b>	*See cable length chart below	
<b>Dimensions and Weight</b>	*See outline drawing	
WIRE CONNECTIONS		
<b>Wire Color</b>	<b>PMA1144 Signal</b>	
<b>Red</b>	Analog Output (0 - 100 mV)	
<b>Blue</b>	Ground	
<b>Black</b>	Cable Shield	
CABLE LENGTHS		
<b>Lab Use</b>	6ft (1.82m) (Removable)	
<b>Outdoor Use</b>	30 ft (10m) (Removable)	
COMPARISON CHART		
Technical Details	PMA1144 (Class II)	PMA1145 (Class I)
Non-linearity (100 to 1000 W/m <sup>2</sup> )	<1.5%	<1%
Spectral Range	300 to 2800nm	285 to 2800nm
Temperature Response	<5% (-10°C to +40°C)	<4% (-10°C to +40°C)
Accuracy of Bubble Level	<0.2°	<0.1°

Part Number: 210042

Revision Level: D

Specifications subject to change without notice.

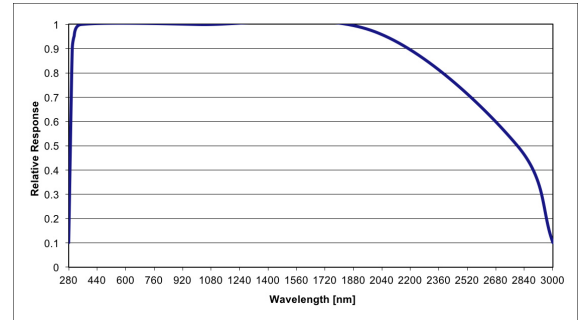

Fig. 1. Linear Spectral Response

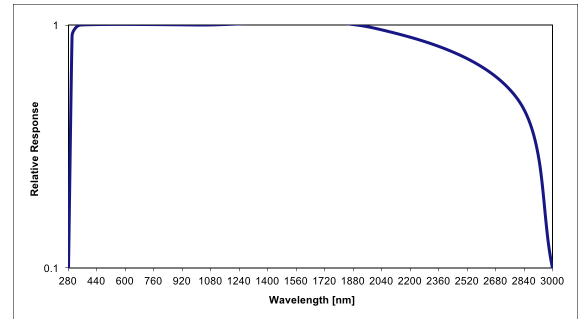
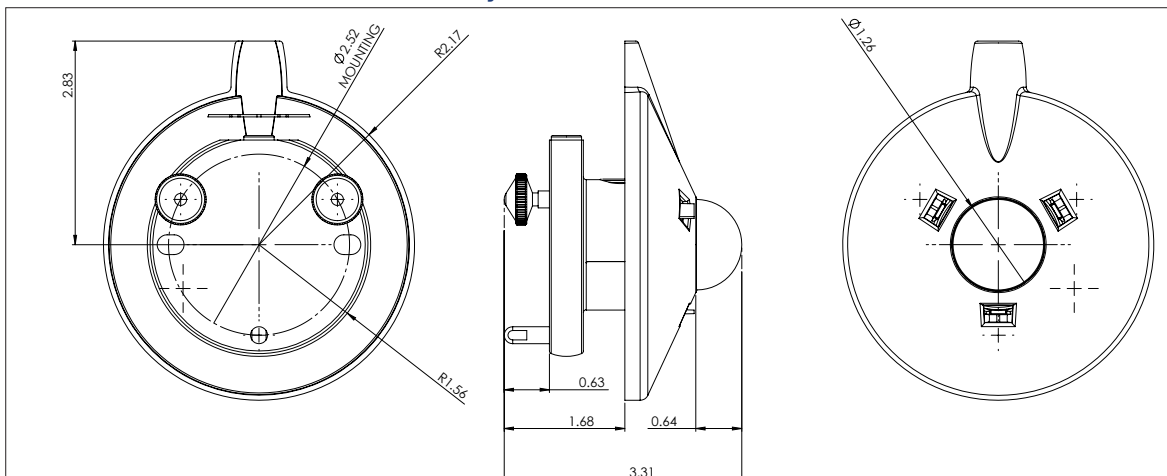

Fig. 2. Log Spectral Response

### Class II Pyranometer Sensor PMA1144



Since 1967, Solar Light Company, LLC has been recognized worldwide as America's premier manufacturer of Precision Solar Simulators and Light Sources, Light Measurement Instrumentation, UV Transmittance Analyzers, Meteorological Instrumentation, and Digital and Analog Sensors. Our advanced line of UV, visible, and IR radiometers and light meters measure laboratory, industrial, environmental, and health related light levels with NIST traceable accuracy. Column ozone, aerosol, and water vapor thickness measurements, in addition to long-term global ultraviolet radiation studies all over the world are performed using our atmospheric line of instrumentation. Solar Light also provides NIST traceable spectroradiometric analyses, calibrations for light meters and light sources, accelerated ultraviolet radiation degradation testing of materials, and OEM instrumentation and monitors. Please visit our website for more details, specifications, and pictures!



**State Of The Art Solar Simulators** available in 150-1000+ watt UV or AM variations for a variety of applications including PV Cell Testing, Materials Testing, Pre-Irradiation for *In Vitro* Broad Spectrum Sunscreen Testing, SPF Testing, and much more.



**Multi-Functional Professional Grade Radiometers** available with and without data logging, and compatible with over 130 Solar Light PMA-Series Sensors to measure UV, Visible and IR wavelengths. Specialty Meters also available to measure UV Radiation, SUV/UVA, Scotopic/Photopic Spectra, and much more.



**Advanced NIST-Traceable Sensors** for accurate measurement of UVA, UVB, UVA+B, UVC, Visible, IR, Photostability, Temperature, and Custom Wavelength – well over 130 models in both digital and analog configurations, all compatible with our Radiometers.



**Ultraviolet Transmittance Analyzers** available as complete integrated turnkey systems to meet the latest ISO24443 requirements.



**Handheld Ozonometers and Sunphotometers** for fast and dependable Column Ozone, Aerosol, and Water Vapor Thickness measurements, in addition to long-term global ultraviolet radiation studies.