

## USER MANUAL

MODEL 511 UV WARNING SIGNAL™



Part Number: 210113  
Revision Level: C



# TABLE OF CONTENTS

<b>1</b>	<b>INTRODUCTION</b>	<b>4</b>
<b>2</b>	<b>COMPONENTS</b>	<b>4</b>
	2.1 Standard Components	4
	2.2 Optional Components	4
<b>3</b>	<b>INSTALLATION</b>	<b>4</b>
	3.1 Mounting	5
	3.1.1 Mounting The Signal	
	3.1.2 Mounting The Sensor	
	3.1.3 Direct Mounting	
	3.1.4 Remote Mounting	
	3.1.5 Plugging Unused Ingress	
	3.1.6 Using Conduit	
	3.2 Wiring Connections	6
	3.2.1 Connecting Sensor Cable	
	3.2.2 Connecting Power Cable	
<b>4</b>	<b>OPERATION</b>	<b>7</b>
	4.1 Power-On Test	7
	4.2 UV Index Indicator Lights	7
	4.3 Steady / Flashing Section	7
	4.4 Show Mode	7
<b>5</b>	<b>CALIBRATION</b>	<b>7</b>
<b>6</b>	<b>SPECIFICATIONS</b>	<b>8</b>
<b>7</b>	<b>MAINTENANCE</b>	<b>8</b>
	7.1 Routine Maintenance	8
<b>8</b>	<b>TROUBLESHOOTING</b>	<b>8</b>
<b>9</b>	<b>APPENDICES</b>	<b>9</b>
	9.1 Appendix A	9
	9.2 Appendix B	10
	9.3 Appendix C	10
<b>10</b>	<b>WARRANTY</b>	<b>10</b>
<b>11</b>	<b>INDEX</b>	<b>11</b>

# 1 INTRODUCTION

The model 511 UV Warning Signal is designed to provide a real-time indication of the sun's UV intensity. Great for outdoor areas; golf courses, country clubs, school yards, outdoor sporting events, amusement parks, ski slopes, beaches, and swimming pools.

The concept behind the UV Warning Signal is that it takes the sun's radiation, changes the UV photons of light in the "skin sensitive range" into an electric signal that corresponds to the *World Health Organization* and *US EPA UV Index* exposure categories. Those exposure categories are represented on the UV Warning Signal by five colored indicator lights. When in operation the UV Warning Signal illuminates the indicator light that corresponds to the level of UV radiation being received by the sensor.

The heart of the unit is the Solar Light Erythema weighted sensor. This sensor is remote mounted for indoor installations of the UV Warning

Signal and can be mounted either remotely or directly on top of the signal for outdoor installations. Hardware is provided for mounting the sensor remotely. Hardware is also included for mounting the signal to a wall or pole. Walls and poles not supplied by Solar Light.

A clear day in the Western US during summer can experience UV Index values as high as 10+. During the winter it can also reach levels of concern. This means a person with Type II skin, unprotected, can burn in a little as 10-15 minutes. In the Northwest part of the US during the summer, the UV Index can reach 9+ while winter values can reach 3+. These are typical average values. The UV Index can vary greatly and is dependent on many factors. It is strongly affected by cloud cover, sun angle, ozone, aerosols, surface albedo, elevation, and other environmental conditions.

# 2 COMPONENTS

See Appendix A for an exploded view of the Model 511 UV Warning Signal.

## 2.1 STANDARD COMPONENTS

- (1) Warning Signal
- (1) Ultraviolet (UV) Sensor
- (1) Sensor Mounting Washer (Rubber)
- (1) Sensor Mounting Bracket
- (1) Sensor Mounting Nut (3/4")
- (2) CD13NR-BK-N-O Cord Grip Fittings
- (2) 7/8" Sealed Button Plug (1/2" Trade Size)
- (1) 10m Sensor Cable
- (1) 100' Low Voltage Power Cable

- (4) Cable Ties
- (1) Plug-In 24VAC Transformer (Indoor Rated)
- (1) Warning Signal Pole Mounting Assembly
- (1) User's Guide

## 2.2 OPTIONAL COMPONENTS

- Outdoor Rated Transformer  
(24VAC Outdoor Transformer, 6 ft Power Cord, Two Cord Grip Fittings)
- Custom Length Sensor Extension Cable
- Custom Length Low Voltage Power Cable
- Warning Signal Reinforcing Plate (For Use With Conduit)

# 3 INSTALLATION

Serious consideration must be given to the installation of the UV Warning Signal. Such items as the location of the signal and sensor, the availability of electrical power, and access to an unobstructed view of the sky will influence how the installation is performed. Considerations such as how to run power cables whether through a building or underground to a mounting pole are not trivial and are beyond the scope of this guide. Consult local electrical professionals for assistance with the installation.

The Model 511 UV Warning Signal conforms to NEC Article 411 "Lighting Systems Operating at 30 Volts or Less."

See Appendix A for an exploded view of the Model 511 UV Warning Signal.

## 3.1 MOUNTING

### 3.1.1 MOUNTING THE SIGNAL

Supplied with the model 511 UV Warning Signal is a set of two assemblies for mounting to a pole. Wall mounting of the 511 is another option.

Wall mounting of the 511 can be accomplished by removing the top cover and securing the enclosure to a wall by the four outer corner holes.

The pole mounting assemblies consist of: two brackets, four 5" hex bolts, four washers, four hex nuts, four 3/4" hex bolts, and two mounting plates. A 1/2" socket or wrench and a 7/16" wrench are required. See Figure 1 for an exploded view of the pole mounting assemblies.

To install the pole mounting assemblies:

- 1 Insert two 5" hex bolts through the inboard holes of each mounting bracket.
- 2 Secure one mounting bracket to the top two corners of the signal with two 3/4" hex bolts. Tighten with 1/2" socket or wrench.
- 3 Secure the second mounting bracket to the bottom two corners in a similar fashion.
- 4 Position the pole to which the signal is to be mounted between the 5" hex bolts of each bracket.
- 5 For each bracket, secure the mounting plate to the 5" hex bolts using the washers and hex nuts and tighten.
- 6 If the sensor is directly mounted on the signal ensure the pole does not obscure the sensor from the sky.

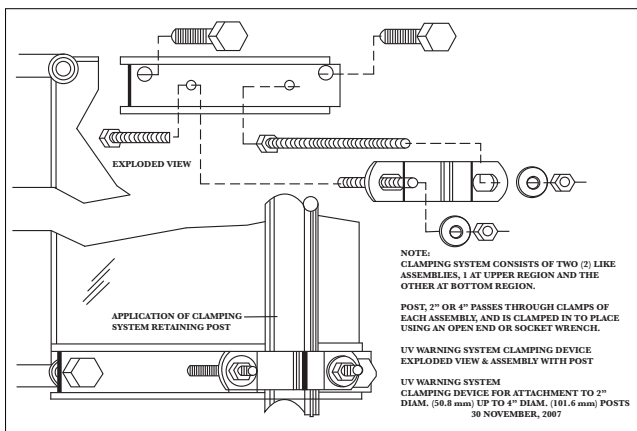

Figure 1 Pole Mounting Diagram

### 3.1.2 MOUNTING THE SENSOR

The model 511 UV Warning Signal was designed to be flexible with regard to installation. As such the UV sensor can be directly mounted on top of the signal or remotely (up to 10 meters) using the sensor mounting bracket and full length of the sensor's cable.

Whether directly or remotely mounting the sensor its orientation is extremely important for accurately measuring UV radiation. The sensor must face straight up toward the sky. This can be checked by laying a small level across the face of the sensor. Adjust the mounting of the sensor accordingly until it is level in all axes.

The placement of the sensor is also very important. It should have a clear view of the entire sky. If this is not possible the sensor should be mounted where it will have the clearest view possible. A significant portion of UV radiation is scattered by molecules and particles in the atmosphere. This causes UV radiation to strike the sensor from all parts of the sky not just from the direct beam so obscuring part of the sky can reduce the amount UV that reaches the sensor causing a lower than actual indicated UV Index category.

### 3.1.3 DIRECT MOUNTING

To mount the sensor directly to the signal:

- 1 Disconnect power to the signal.
- 2 Open the signal by removing the six lid screws.
- 3 On the top end of the signal (with one 7/8" hole) place the sensor mounting washer on the outside of the hole then insert the threaded base of the sensor through the hole.
- 4 Hand-tighten the sensor to the signal using the 3/4" sensor mounting nut.
- 5 Connect the sensor cable to the sensor and slide the locking sleeve forward.
- 6 For sensor cable wiring see "Connecting Sensor Cable."
- 7 Replace the signal lid and secure with the six lid screws.
- 8 Reconnect power to the signal.

### 3.1.4 REMOTE MOUNTING

To mount the sensor remotely:

- 1 Secure the sensor mounting bracket in a location with an unobstructed view of the whole sky.
- 2 Ensure that the bracket is level.
- 3 Insert the threaded base of the sensor through the 3/4" hole in the bracket.
- 4 Hand-tighten the sensor to the bracket using the 3/4" sensor mounting nut.
- 5 Connect the sensor cable to the sensor and slide the locking sleeve forward.
- 6 Secure a cord grip fitting into the left 7/8" hole in the bottom of the signal.
- 7 Feed the sensor cable through the fitting and tighten.
- 8 For sensor cable wiring see "Connecting Sensor Cable."

### 3.1.5 PLUGGING UNUSED INGRESS

There are three 7/8" ingress points on the signal of which two will be used: one for the sensor/cable and one for the power cable. The third unused hole will be plugged using the supplied 7/8" button plug and spacer. The spacer is provided to ensure a tight seal.

The recommended scheme is to plug the bottom left hole when the sensor is mounted directly to the top of the signal but to plug the top hole when the sensor is mounted remotely. The cord grip fittings are

liquid-tight however the best practice for guarding against leaks is to use them on the bottom so that water drains off and does not pool on them as it would if they were on top.

To insert the button plug:

- 1 Disconnect power to the signal.
- 2 Open the signal by removing the six lid screws.
- 3 From outside the signal, snap the button plug into the unused ingress point *(As described above.)*
- 4 From inside the signal, snap the spacer over the retaining lip of the button plug.
- 5 Replace the signal lid and secure with the six lid screws.
- 6 Reconnect power to the signal.

### 3.1.6 USING CONDUIT

The three ingress points on the signal are standard NEMA 7/8" (½" trade conduit size) knockouts. The low voltage power supplied to the signal does not require the use of conduit to run the cabling however in certain cases it may be desirable to use conduit for running power and/or sensor cables.

If using conduit, the optional reinforcing plate should be used to guard against the strain applied to the signal by the conduit and fittings. Contact Solar Light to order the optional reinforcing plate.

## 3.2 WIRING CONNECTIONS

The internal wiring of the model 511 UV Warning Signal is performed at the factory. The only wiring required by the user is to connect the power and sensor cables. Perform the steps outlined in the mounting section before wiring the sensor and power cables.

See Appendix B for complete wiring diagram.

### 3.2.1 CONNECTING SENSOR CABLE

Ten meters of sensor cable is provided. Once the sensor and signal are mounted and the required length of cable is determined, spool excess cable inside the signal. Sensor extension cables are available if longer than ten meters of cable is needed. Contact Solar Light if longer cabling is required.

The red connector mates with the sensor jack located on the power supply/driver board.

To connect the sensor cable:

- 1 Disconnect the power to the signal.
- 2 Plug red connector on the sensor jack located on the power supply/driver board. (Shipped installed)
- 3 Set switch 6, located on the power supply/driver board, to "OFF" *(If unit was in demo mode.)*
- 4 Replace the signal lid and secure with the six lid screws.
- 5 Reconnect power to the signal.

### 3.2.2 CONNECTING POWER CABLE

One hundred feet of power cable and a 24VAC plug-in transformer are provided with the model 511 UV Warning Signal. Contact Solar Light to order the optional outdoor transformer. Once the signal is mounted and the required length of cable is determined, excess cable may either be cut or spooled inside the signal. Allow one foot extra for wiring inside the signal if cutting the cable.

You will need a narrow flathead screwdriver. To connect the power cable:

- 1 Disconnect the power to the signal.
- 2 Strip about 6" of the outer insulation of the power cable and separate the individual wires. Strip ½" insulation off of each individual wire
- 3 Loosen the cord grip nut and insert the power cable thru the grip about one foot and tighten the nut
- 4 Open the signal by removing the six lid screws.
- 5 Open the case. Take the power cable and bend it out of the case. Place the front of the display in the back part of the case, secure if necessary.
- 6 Connect the Red and Black wires to the (2) 24VAC terminals and the Blue wire to GND. *Note the colors used at each terminal.*
- 7 Replace the signal lid and secure with the six lid screws.
- 8 Connect the wires at the other end of the cable to the terminals on the 24VAC plug-in transformer *(usually done at the factory).*
  - a) Specification: 110VAC to 24VAC, grounded, wallmount ELK-TRG2440, ELK Products, Inc.
  - b) Connect the Blue wire going to GND to the center ground terminal.
  - c) Connect Red and Black wires going to 24VAC terminals to the outer AC terminals.
- 9 Plug transformer into 110VAC outlet or 220 to 110VAC step down transformer.

# 4 OPERATION

## 4.1 POWER-ON TEST

The model 511 UV Warning Signal conducts a test when power is supplied. The five UV Index indicator lights flash from green thru violet twice before switching to normal operation. The test allows for inspection of the high output LEDs to determine if any need to be replaced. The LEDs have an operational lifetime of 50,000+ hours.

## 4.2 UV INDEX INDICATOR LIGHTS

The UV Index indicator lights are high output LEDs capable of viewing up to 150 feet away in direct sunlight. The indicator lights are visible in a large viewing angle up to 45 degrees off axis. The five UV Index indicator lights are colored to match the *World Health Organization* and *U.S. EPA* exposure categories. The UV Index values are grouped into these exposure categories and recommended sun protection is expressed for each category. See the table below.

EXPOSURE CATEGORY	UV INDEX RANGE	COLOR	RECOMMENDED ACTION
Extreme	11+	Purple	Avoid being outside during midday hours. Seek shade. Shirt, sunscreen and hat a must.
Very High	8-10	Red	
High	6-7	Orange	Seek shade during midday hours. Wear a shirt, sunscreen, and hat.
Moderate	3-5	Yellow	
Low	0-2	Green	No protection required.

## 4.3 STEADY/FLASHING SELECTION

By default the UV Index indicator lights are set to steady illumination. For increased visibility each of the five indicator lights can be independently switched to flashing.

To toggle an indicator light from steady to flashing:

- 1 Disconnect the power to the signal.
- 2 Open the signal by removing the six lid screws
- 3 Switch the corresponding dip switch to the “OFF” position for continuous on or “ON” for flashing. There are five switches, one for each indicator light.
- 4 Replace the signal lid and secure with the six lid screws.
- 5 Reconnect the power to the signal.

## 4.4 SHOW MODE

To enable show mode on the Model 511 UV Warning Signal enable switch 6 to the **ON** position. To enable Field Mode, return switch 6 to the **OFF** Position.

# 5 CALIBRATION

Biannual calibration of the sensor is recommended. The sensor can be sent to Solar Light’s calibration facility in Glenside, PA. The calibration service utilizes a revolving network of calibrated sensors. The sensor can be disconnected from the cable and mounting bracket and returned to Solar Light. *Only the sensor is to be returned for calibration.*

The Global Solar UV Index is determined using the International Commission on Illumination (CIE) reference action spectrum for UV-induced Erythema on human skin (ISO 17166:1999/CIE S 007/E-1998). It is a measure of UV radiation that is defined for a horizontal surface. The UV Index is a unitless quantity defined by the formula:

$$I_{UV} = k_{er} \cdot \int_{250nm}^{400nm} E_{\lambda} \cdot S_{er}(\lambda) d\lambda$$

Where  $E_{\lambda}$  is the solar spectral irradiance in  $W/(m^2 \text{ nm})$ .  $S_{er}(\lambda)$  is the Erythema action spectrum and  $k_{er}$  is a constant equal to  $40 \text{ m}^2/W$ .

The sensor is calibrated traceable to the National Institute of Standards and Technology (NIST) for the global solar irradiance under the following atmospheric conditions: clear sky,  $30^{\circ}$  solar zenith angle, 2.7mm ozone column thickness, zero surface albedo, sea level elevation.

# 6 SPECIFICATIONS

SPECIFICATIONS	
Spectral Response	Appendix C
Angular Response	±5% Incident Angles <70°, Appendix D
Measurement Range	0-16 UV Index
Power Requirements	110 VAC, 60Hz
Operating Environment	Indoor/Outdoor
Operating Ambient Temperature	-20-130°F (-30-55°C)
Storage Temperature	-20-130°F (-30-55°C)
Height	22" (55.88 cm) or 24" (60.96 cm) with Sensor & Cord Grip
Width	11" (27.94 cm)
Depth	7" (17.78 cm)
Shipping Weight	20 lbs. (9.07 kg)
Sensor Cable Length	10m (32.8 ft)
Power Cable Length	100 ft (30.48 m)
Ingress Points	7/8" (1/2" trade size)
Pole Mounting Diameter	2" Min, 4" Max (5.08 cm Min, 10.16 Max)

# 7 MAINTENANCE

The model 511 UV Warning Signal is an automatic measuring and signaling system. As with any measurement and signaling system, some minimum maintenance is required to ensure reliable operation.

## 7.1 ROUTINE MAINTENANCE

The following maintenance schedule is recommended but some changes may be necessary depending on the operating environment and other limitations

Snow, frost, drops of water, dirt, or other contaminants on the sensor may change the indicated UV Index significantly, and therefore cleaning the sensor regularly is very important.

FREQUENCY	OPERATION
As Necessary	Cleaning of the sensor, power-on test to check UV Index indicator lights.
Annually	Sensor recalibration by manufacturer, installation checkup. (Sensor cable, power cable, transformer, conduit connections, mounting hardware.)



# 8 TROUBLESHOOTING

In this chapter some problems that a user can face when using the 511 UV Warning Signal are described. If there are any malfunction symptoms, good practice is to first cycle the power, then check that:

- All cables are correctly plugged in
- The power is properly supplied
- The sensor is installed according to the chapter “Installation”

Some specific situations are described below in convention: symptom, possible cause and correction:

- There is no indicator light illuminated:
  - The sensor does not have a clear view of the sky; position the sensor so that it has a clear view of the sky.
  - UV level is less than 1 UV Index; the lowest UV indicator light (green) does not illuminate with UV Index less than one. Many mid and high latitude locations may have wintertime UV Index levels less than one for most or all of the day, especially when overcast.
  - The power is disconnected; check that the transformer is plugged into a powered wall outlet.
  - The sensor is not connected; check that the sensor is properly

connected to the sensor cable and that the locking sleeve is slid forward into its locked position.

- The sensor or power connection inside the signal has come loose or is miswired; see the wiring section in chapter “Installation” and consult the wiring diagram in Appendix B.
- There is water inside the signal:
  - The rubber sensor mounting washer (if directly mounted) is missing or deteriorated; replace washer with a suitable replacement or contact Solar Light for a replacement washer. See chapter “Installation.”
  - The sensor (if directly mounted) is not tightly secured to the signal; disconnect power, open the signal lid, hand-tighten the mounting nut, close lid and reconnect power.
  - A cord grip fitting is loose; tighten fitting to secure the cable and tighten mounting nut inside the signal. See chapter “Installation.”
  - The button plug is loose or deteriorated; contact Solar Light for a replacement button plug and spacer. See chapter “Installation” for installing the button plug and spacer.

# 9 APPENDICES

## 9.1 APPENDIX A

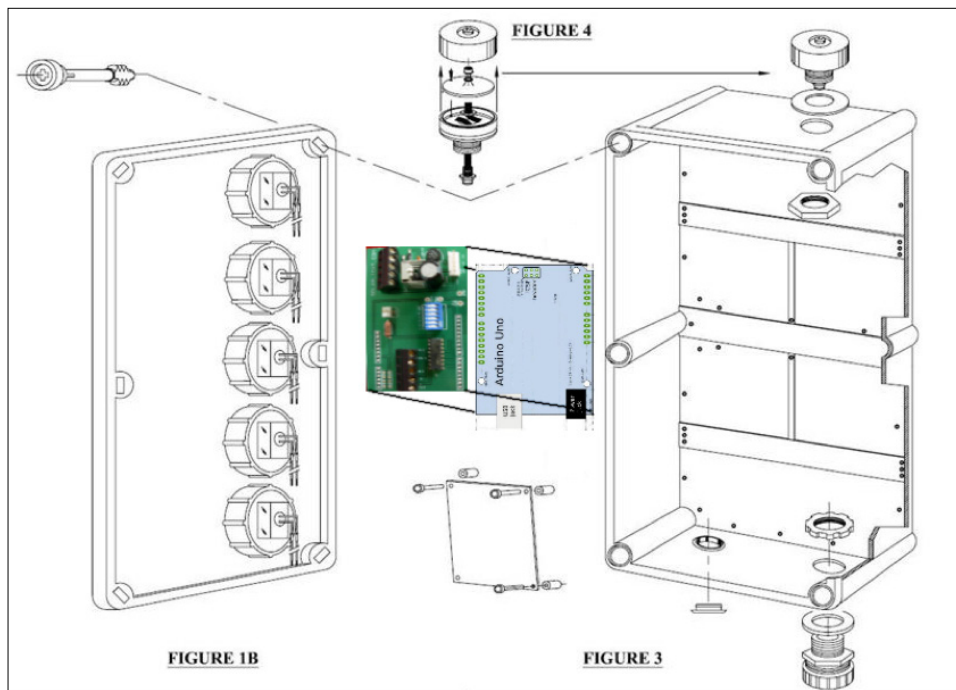

Figure 2 Model 511 Exploded View

## 9.2 APPENDIX B

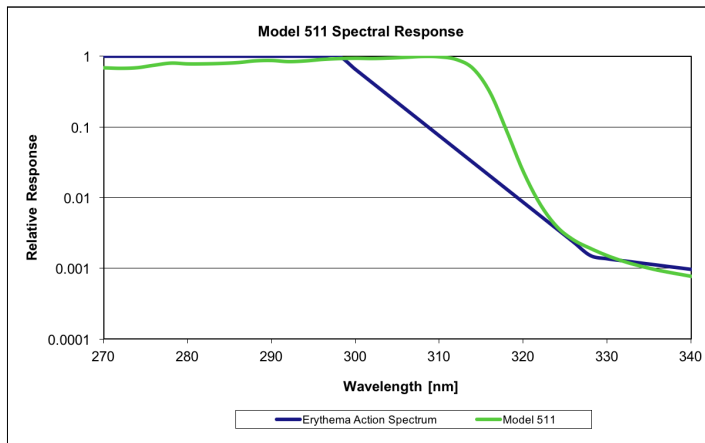

Figure 3 Model 511 Spectral Response

## 9.3 APPENDIX C

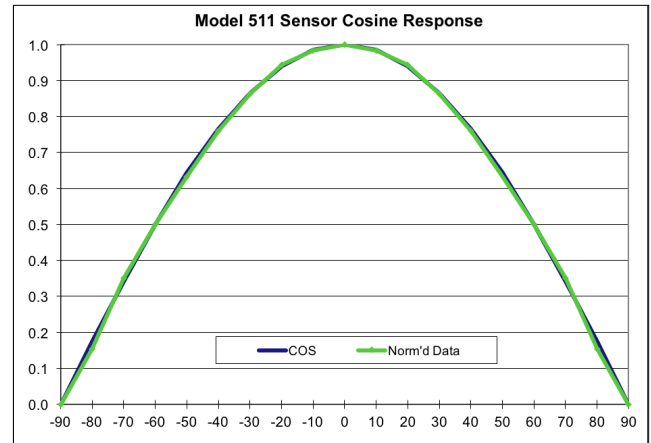

Figure 4 Model 511 Angular Response

# 10 WARRANTY

**SOLAR LIGHT COMPANY** warrants that the equipment has been carefully tested, inspected and left the Factory in proper working condition, free of visible defects. Solar Light Company warrants the equipment to be free from defects in material and workmanship, under normal use and operation, for a period of one (1) year after the date of initial operation, or demonstration; or eighteen (18) months from the date of shipment from the Factory; or whichever occurs first.

The warranty is limited to the free replacement of all-defective parts and free labor during the first year of warranty. Defective parts replaced under this warranty shall become the property of Solar Light Company.

The above stated Warranty is subject to the following conditions: Return of the warranty registration card to Solar Light Company, completed and properly signed, within thirty (30) days after the initial operation or demonstration of the equipment.

Equipment being installed within the United States of America, Canada, or sold by authorized Solar Light Company representatives or their agents outside the continental United States.

The equipment being installed is operated and maintained in accordance with Solar Light Company's operating instructions, maintenance instructions and specifications.

Utilization of only Solar Light Company's authorized parts and components. The utilization of a duly authorized representative for all work performed on Solar Light Company equipment during the warranty period. Any variation(s) to the above warranty must be in writing and mutually acceptable by Solar Light Company and the customer.

The warranty shall not apply to damages resulting from errors in installation, nor shall it apply to any equipment, which has been subject to damages, alterations or misuse by the purchaser. Parts of the equipment, which would be generally considered as expendable service items during normal use, such as fuses, lamps, detector shields, etc., are not covered under the warranty.

All other warranty, express or implied, including without limitation, any implied warranty of merchantability or fitness for a particular purpose, are hereby disclaimed by us and excluded from these terms. Specifically, but without limitation, we give no express or implied warranties as to whether the specifications will satisfy the requirements of you or your customers or any other matter relating to the specifications, results obtained or obtainable from the products, other services performed by us, our servants or agents, nor that the products developed and manufactured by us or on our advice will be suitable for any particular purpose or for use under any specific conditions, notwithstanding that such purpose or conditions may be known or made known to us. In no event shall Solar Light Company be liable for special, incidental, or consequential damages or anticipated loss of profits suffered by the purchaser.

<b>A</b>		<b>S</b>	
Albedo.....	4,7	Sensor Cable.....	4,5,6,9
Angular Response.....	8,10	Sensor Extension Cable.....	4,6
<b>B</b>		Sensor Mounting Bracket.....	4,5
Button Plug.....	4,5,6,9	Sensor Mounting Nut.....	4,5
<b>C</b>		Shipping Weight.....	8
Calibration.....	7,8	Solar Zenith Angle.....	7
CIE.....	7	Spectral Response.....	8
Conduit.....	4,6	Standard Components.....	4
Cord Grip Fittings.....	4,5	<b>T</b>	
<b>E</b>		Transformer.....	4,6,8,9
Erythema.....	4,7	Troubleshooting.....	8
Exposure Categories.....	4,7	Type II Skin.....	4
<b>F</b>		<b>U</b>	
Flashing.....	7	U.S. EPA.....	7
<b>I</b>		Ultraviolet.....	4
Indicator Lights.....	7,8	UV.....	4,5,7,9
Ingress Points.....	5,6,8	UV Index.....	4,7,8,9
Installation.....	4,5,8,9,11	<b>W</b>	
Irradiance.....	7	Warranty.....	11
<b>L</b>		Wiring.....	5,6,9
Low Voltage.....	4,6	World Health Organization.....	4,7
<b>M</b>			
Maintenance.....	8,11		
Measurement Range.....	8		
Mounting.....	4,5,6,7,8,9		
<b>N</b>			
NEC Article 411.....	4		
NEMA.....	6		
NIST.....	7		
<b>O</b>			
Operating Environment.....	8		
Optional Components.....	4		
Ozone.....	4,7		
<b>P</b>			
Pole Mounting Assemblies.....	5		
Pole Mounting Diagram.....	5		
Power Cable.....	4,5,6,8		
Power Requirements.....	8		
Power-On Test.....	7,8		
<b>R</b>			
Radiation.....	4,5,7		
Reinforcing Plate.....	4,6		