

Design, calibration and performance of MICROTOPS II hand-held ozonometer

Marian Morys

Solar Light Co. Inc., Philadelphia PA 19126

Forrest M. Mims III

Sunphotometric Atmospheric Network, Seguin TX, 78155

Stanley E. Anderson

Westmont College, Santa Barbara, CA 93108

Abstract

MICROTOPS II, a 5-channel hand-held sunphotometer with center wavelengths of 300, 305.5, 312.5, 940 and 1020nm was designed to allow quick and inexpensive measurements of the total ozone column and water vapor column. The 2.5nm FWHM for the UV channels was selected to balance noise and ozone measurement performance. The total ozone column is automatically calculated based on measurements at 3 UV wavelengths, the site's latitude and longitude, universal time, altitude and pressure. A built-in pressure transducer facilitates the measurement. Two IR channels allow measurement of total precipitable water in the atmosphere. Critical aspects of the design described in the paper include: stray light rejection, thermal and long term stability, signal/noise optimization, collimation, targeting and data analysis. MICROTOPS II performance is tested by comparing to Dobson spectrophotometers.

Introduction

The intensity of ultraviolet radiation at the surface of the Earth is modulated by aerosols and ozone within the atmosphere. Since ozone absorbs shorter wavelengths more effectively than longer wavelengths, the ratio of the intensity of direct sunlight at two wavelengths within the range of 300 to 320 nm is related to the total abundance of ozone in a column through the atmosphere. This forms the basic operating principle a variety of instruments that measure the ozone layer. The best known such instruments are the Dobson and Brewer spectrophotometers. Both these instruments divide sunlight into its constituent wavelengths by means of a spectrometer. The dispersing element in the Dobson is a quartz prism in the Dobson and a diffraction grating in the Brewer.

Filter Ozonometers

Filter-based ozonometers are much smaller and less costly than spectrometer instruments. Their performance, however, is less than desirable due in large part to the wider spectral passband of filters. Optical filters of the glass absorption type are used in the Russian M-83 spectrometer.(1,2) This instrument has been compared with a Dobson spectrometer by Bojkov (3), who found large differences between the measured ozone values of the two instruments of up to 30%. Osherovich found even greater discrepancies in his analysis.(4) The discrepancies have been attributed to the fairly wide filter bandwidth of about 25-30 nm. Therefore, the monochromatic Beer-Lambert law is inapplicable, and even corrections based on the accurate ozone spectrum cannot easily be applied because of atmospheric aerosol scattering effects. Other drawbacks of the M-83 include its wide field of view and analog meter readout. While the M-83 has been supplanted by the newer and better designed M-124, the filter bandpass, field of view and analog output limitations remain.

Ozonometers based on narrow-bandpass interference filters were first developed nearly thirty years ago, the first instrument having been described by Osherovich.(5) Osherovich (6) and Steblova (7) subsequently reported on its use. Matthews and Basher (8-10) developed an ozonometer for New Zealand's national atmospheric monitoring laboratory that used narrow-bandpass interference filters. The peak wavelengths of the filters were closely matched to the wavelengths used by the Dobson spectrometer.

Limitations of Filter Ozonometers

The key limitations of ozonometers which use narrow-bandpass interference filters have been reviewed in detail by Basher and Matthews (11) and Basher (12). The most important difficulties with early interference filter instruments were imperfect monochromaticity, bandwidth, temperature dependencies, orientation of the filters, radiation leakage, and aging of the filters which produce a gradual shift of the center wavelength. The latter shift has been attributed to changes in dimensionality due to reaction with absorbed moisture. This can be solved to some extent by hermetically sealing the filter.

Interference filters are susceptible to the radiation-induced aging known as solarization. This can be reduced with blocking filters placed before the interference filter. There is also the problem of manufacturing the filters to closely repeatable tolerances which is related to the difficulty of accurately depositing the many thin layers which comprise an interference filter. Many of these early problems in fabricating interference filters have been overcome by advances in technology. Filters having bandwidth of 1 nm or less are now available. (13) Metal oxide layers are much more resistant to aging and solarization. While filters cannot currently be made with absolutely identical performance specifications, they probably can be manufactured with tolerances of 1-2%.

Total Ozone Portable Spectrometer (TOPS)

Mims applied the work of Basher and Matthews and high quality interference filters to the development of a miniature, hand-held filter ozonometer known as Total Ozone Portable Spectrometer (TOPS). (14, 15) Two TOPS were calibrated against the Total Ozone Mapping Spectrometer (TOMS) aboard NASA's Nimbus-7 satellite in the fall of 1990. These instruments measured fluctuations in the ozone layer during the total solar eclipse of 1991 (16), reduced ozone following the eruption of Pinatubo in 1991 (17), and an extrapolated calibration drift in the Nimbus-7 TOMS (18,19).

Microprocessor-Controlled TOPS (MicroTOPS).

The success of TOPS resulted in a 1993 Rolex Award (20) which funded the development of a microprocessor-controlled version of the instrument known as Microtops. Microtops is a Sun photometer with 5 channels: 297, 303, 310, 940 and 1020 nm. The 3 UV channels measure total column ozone and direct UV-B. The ratio of the 940 and 1020 nm channels permits the measurement of total column water vapor. The 1020 nm channel measures the optical thickness of the atmosphere at one of the principle wavelengths used for this purpose by the Stratospheric Aerosol and Gas Experiment (SAGE) satellite. Microtops was designed by Scott Hagerup, and 32 were fabricated by Advanced Concept Electronics. Twenty Microtops monitored the ozone layer from Baja, California, to New Hampshire during the annular solar eclipse of 10 May 1994. Many of these instruments observed fluctuations in the ozone during the eclipse (Mims et al., paper in preparation).

A Microtops having UV filters with a bandpass of 7 nm was compared with a Brewer spectrophotometer by Labow and Flynn (21, 22). This independent comparison established that ozone retrievals from the Microtops were typically within 2% of those by the Brewer. A Microtops with 2.2 nm (Supertops) filters was calibrated against world standard Dobson spectrometer 83 at Mauna Loa Observatory during June 1994. During a second comparison in June 1995, Supertops yielded ozone amounts typically within 1% of those by Dobson 83. Supertops was the first instrument to detect record low ozone over the southern United States during fall 1994. (23)

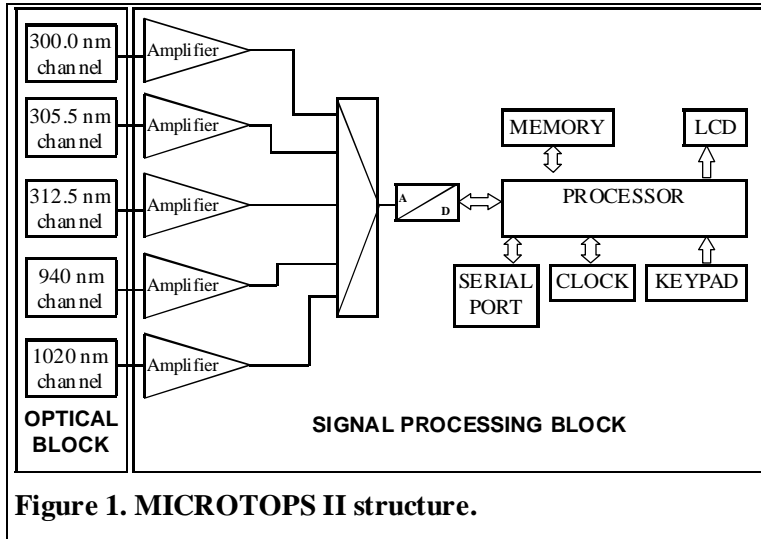

Microtops II

The success of the narrow-bandpass filters used in Supertops led to the decision to use similar filters and wavelengths in Microtops II, the significantly advanced version of Microtops which is the subject of the remainder of this report. Microtops II is designed at Solar Light Company. The instrument stores 800 scans of all 5 channels, the time and date, the geographic coordinates (which are entered manually into the instrument's keypad or automatically by a Global Positioning Satellite

receiver), the temperature inside the instrument and the barometric pressure. A self-contained microcomputer automatically calculates the solar zenith angle, the ozone mass (μu) and the total column amounts of ozone and water vapor. The field of view of each of the optical channels is 2.5° making it suitable for other sunphotometric measurements.

Instrument design

The overall structure of MICROTOPS II is shown in Figure 1. The optical block is shaping the field of view of the instrument, filtering the incoming radiation, detecting it and facilitating targeting at the sun. The electrical signals from photodetectors are amplified, converted to a digital form and numerically processed in the signal processing block.

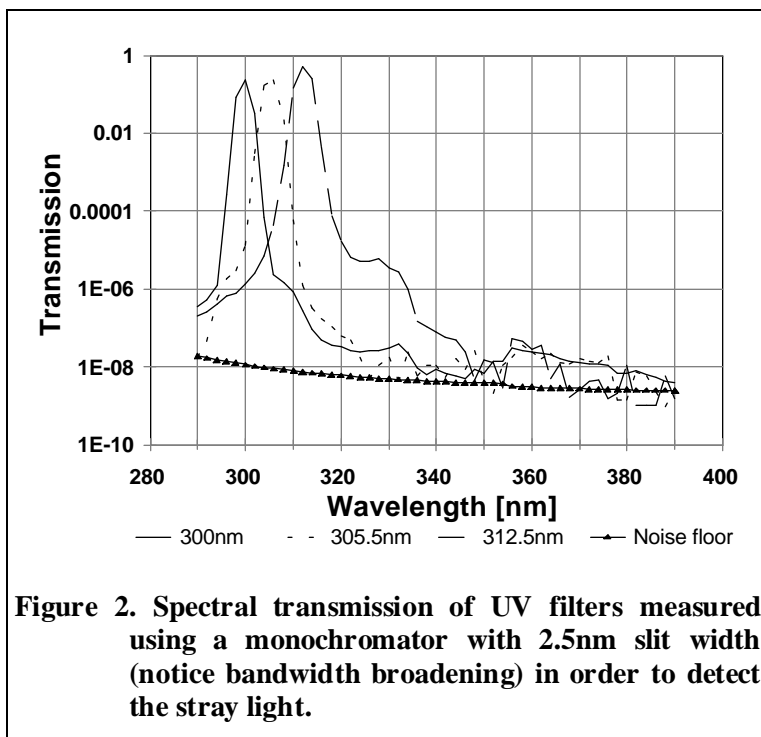

Optical block

The success of the instrument depends on its ability to measure ozone column with long term stability under broad range of air masses and atmospheric conditions.

The entire instrument and all subsystems were analyzed in a series of computer simulations. The initial design goal of an overall precision better than 3%, for air mass up to 3, translated, into a set of very stringent specifications. Several iterations of the process allowed us to find a set of specifications that met the initial criteria and were realistic at the same time.

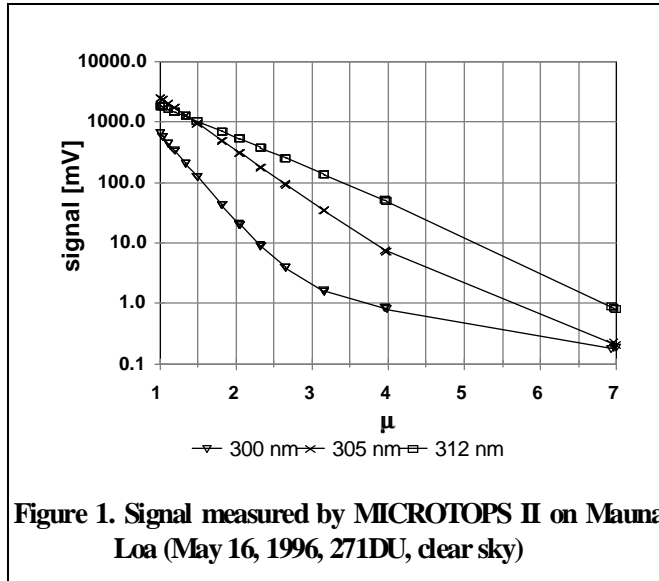

Figure 1. Signal measured by MICROTOPS II on Mauna Loa (May 16, 1996, 271DU, clear sky)

Described below are some of the critical issues considered during the design process:

- To assure long term stability the optical block is machined from a cast aluminum plate.
- The mechanical alignment of the optical channels is better than 0.1° .
- Internal baffles in each channel prevent the 1st and 2nd reflections from reaching the photodetector. The internal surfaces of the collimators are lined with a low-reflectivity material.
- The sun-targeting hardware is machined from aluminum and directly attached to the filter

block to avoid temperature effects on targeting.

- The entire optical block is suspended in the enclosure in such a way that a mechanical strain applied to the enclosure does not result in substantial strain in the optical block.
- The sun targeting assembly is laser-aligned to within 0.1° from the optical axis of the block.
- The temperature of the optical block is monitored and logged in order to allow temperature compensation if needed.
- A built-in solid state pressure sensor provides the current atmospheric pressure needed for Rayleigh scattering calculation.

Special consideration was given to the optical filters and photodetectors, particularly for the UV channels. The most critical, and difficult to meet, was the requirement for high out-of-band rejection. The computer simulation called for leakage no greater than 10^{-7} ($\lambda < 650\text{nm}$) for 300nm filters. Lower wavelength filters have more strict

Table 1 UV filters specifications

| | FILTER 1 | FILTER 2 | FILTER 3 |
|---|--|--|--|
| Center Wavelength | 300nm $\pm 0.3\text{nm}$ | 305.5nm $\pm 0.3\text{nm}$ | 312.5nm $\pm 0.3\text{nm}$ |
| FWHM | 2.4nm $\pm 0.4\text{nm}$ | 2.4nm $\pm 0.4\text{nm}$ | 2.4nm $\pm 0.4\text{nm}$ |
| Angle of incidence | 0 | 0 | 0 |
| Max. out of band transmission (relative to peak) | $10^{-7} \lambda < 650\text{nm}$ $10^{-5} \lambda > 650\text{nm}$ | $10^{-6} \lambda < 650\text{nm}$ $10^{-4} \lambda > 650\text{nm}$ | $10^{-5} \lambda < 650\text{nm}$ $10^{-4} \lambda > 650\text{nm}$ |
| Min. peak transmission | 15% | | |
| Temp. coef. of center wavelength | $< 0.005 \text{ nm}/^\circ\text{C}$ | | |
| Wet/dry shift | $< 0.1\text{nm}$ | | |
| Long term stability | $< 0.1\text{nm}/\text{year}$ | | |
| Operating environment | temp: -20 .. +40°C; hum: 0 ... 100%; | | |

leakage requirements because the in-band signal is weaker than that at higher wavelengths. Typical shape of the filter's transmission is shown in **Error! Reference source not found.**. The repeatability of center wavelength and FWHM within a batch was in the order of 0.1nm. The novel technology of depositing the filter's layers and coatings assures long life and stability.

The GaP photodetectors used in the MICROTOPS II are characterized by relatively strong sensitivity in the UV region, low noise level and low sensitivity above 500nm. These characteristics allowed us to relax the out-of-band rejection above 650nm lowering the production cost of the filters. The photodetectors are hermetically packaged to assure long life and stability.

Signal conditioning and processing

The solar radiation at short UV wavelengths decreases rapidly with increasing air mass (**Error! Reference source not found.**). The slope increases as the ozone layer increases. In order to measure the ozone column the MICROTOPS II measures each wavelength independently and then calculates the ratio, unlike the Dobson instrument, which benefits from the differential approach. In order to perform accurately, the MICROTOPS II must be able to measure very weak and very strong signals with adequate signal-to-noise ratio and high linearity. To achieve that goal the following approach was taken:

- The input amplification stages were optimized to have the lowest noise level. The dominant noise source in the most sensitive channels is the thermal noise of the feedback resistance in the amplifier. The band-width of all amplifiers reduced cut to a minimum and kept equal for all channels. With a band-width of just under 10Hz the max. RMS amplifier output noise is 5.8 μ V.
- A high performance sigma-delta A/D converter with on-chip digital filtering is used. The high over-sampling ratio of this converter eliminates the need for high-order anti-aliasing filters at the front-end. The conversion non-linearity is less than 0.0015% within the entire input range and the A/D conversion noise level is 5.3 μ V RMS with 2.5V full scale.
- The A/D converter's filter is programmed to reject line frequency interference (user selectable).
- Each measurement cycle comprises multiple measurements of all channels that are processed numerically in order to lower the noise level and improve overall accuracy.
- Attention was paid to proper shielding and optimal layout of the amplifiers and the conversion block.

Overall, the dynamic range achieved in the instrument is over 300,000 with excellent linearity leaving adequate signal-to noise margins even for very weak signals.

To assure long term stability of measurements the electronic circuitry itself has to be very stable, both thermally and long term. The gain of the amplifiers is determined by a set of precision resistors with temperature coefficients below 0.005%/°C. The amplifier's offset is automatically compensated every time the instrument is powered on. Both the offset and full scale of the A/D converter are automatically calibrated before each scan. The full scale calibration relies on a high performance voltage reference with the temperature coefficient under 0.001%/°C and long term stability in the order of 0.005%/year. Careful design of the signal conditioning and processing block reduces the effect of any electrical instability to a negligible level simplifying characterization and calibration of the instrument.

Real time and date for the solar zenith angle calculation is provided by the on-board clock. The inherent accuracy of low-power crystal clocks is not adequate for long periods of time, therefore a clock trimming mechanism is implemented in the software. The user can enter the clock correction in seconds/30 days and the program will periodically skip (or add) a few seconds in order to maintain the clock accuracy to within 5 seconds.

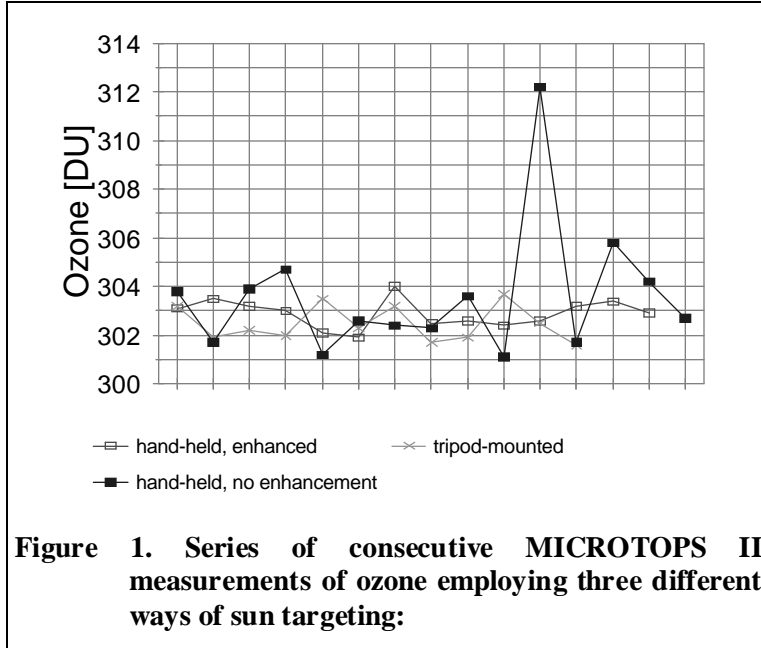

Figure 1. Series of consecutive MICROTOPS II measurements of ozone employing three different ways of sun targeting:

Sun targeting

While optionally equipped with the hardware for tripod mounting, the MICROTOPS II is designed primarily for hand-held operation. There is a concern about the accuracy of pointing the meter towards the sun. A series of tests indicated that in the hands of a well trained operator the instrument can move up to 1° off the sun's center. Presence of strong wind or cold weather may further degrade the steadiness of the operator's hand.

To enhance the sun targeting accuracy in the MICROTOPS II an algorithm was implemented that analyses a series of rapidly repeated measurements. A signal

strength factor is calculated based on the signal from all 3 UV channels. Only the records with highest ranking signal strength factor are averaged and passed for further processing.

The total number of measurements in a scan as well as the number of records averaged can be set by the user.

Figure 1 presents the results of three consecutive series of ozone measurements performed on fairly clear day, with the same instrument. Each of the measurement series employs different sun targeting technique: hand-held with targeting enhancement based on a series of 32 rapid measurements (measurement time approx. 10 seconds), hand-held with just averaging of measurements and the third series was measured with MICROTOPS II mounted on a tripod.

Table 1 shows the standard deviation of each measurement series, the hand-held with targeting enhancement offering the most repeatable results with a standard deviation of 0.18%. The targeting enhancement produces results slightly better than tripod-mounted instrument by compensating the targeting error due to limited resolution of the instrument's targeting system.

Calibration and measurement of ozone

Calibration of the MICROTOPS II instrument requires that the intensity of radiation measured at each channel be analyzed assuming the validity of the Lambert-Beer law, which when applied to ozone absorption and Rayleigh scattering by the atmosphere, gives the simple equation

$$I = I_0 e^{-\alpha \mu \Omega - m \beta P / P_0}$$

(1)

I_0 is the intensity of the light of a particular wavelength before it passes through the atmosphere, I , the intensity remaining after all processes attenuating the incident radiation have occurred, Ω is the amount of ozone, α is the ozone absorption coefficient at that specific wavelength, μ the ratio of the actual and vertical path lengths of the radiation through the ozone layer, P is the pressure of the atmosphere in mb, P_0

is standard pressure = 1013.25 mb, and m is a quantity known as the airmass, which is defined as the ratio of the actual and vertical path lengths of the radiation through the entire atmosphere to the detector. For $m < 2$ the μ and m are virtually identical. Other processes including molecular scattering (Rayleigh scattering coefficient

Table 1 Performance of sun targeting methods.

| Targeting method | Standard deviation |
|---------------------------|--------------------|
| Hand-held, no enhancement | 0.87% |
| Hand-held, enhanced | 0.18% |
| Tripod mounted | 0.23% |

represented by β) by the atmosphere, and particulate scattering produced by haze (water plus atmospheric pollutants of micron particle size) are included as shown into the exponent for a complete representation of atmospheric attenuation. It is customary to ignore the particulate scattering. Studies have shown that even the worst haze conditions do not effect ozone measurements by more than a few percent and much less under usual conditions.⁷

Expressions for μ and m quantities are as follows:^{8,9}

$$m = \sec Z - 0.0018167 \cdot (\sec Z - 1) - 0.002875 \cdot (\sec Z - 1)^2 - 0.0008083 \cdot (\sec Z - 1)^3 \quad (2)$$

$$\mu = \frac{R + h}{\left[(R + h)^2 - (R + r)^2 \sin^2 Z \right]^{1/2}} \quad (3)$$

or more conveniently,
$$\mu = \frac{1}{\sqrt{1 - v \cdot \sin^2 Z}}, \quad (4)$$

where v is a geometric factor for the height of the ozone layer given by

$$v = \frac{(R + r)^2}{(R + h)^2}, \quad (5)$$

R = mean earth radius (6371 km),

r = height of ozone station above sea level in km

and h = height of ozone layer above sea level approximated as :

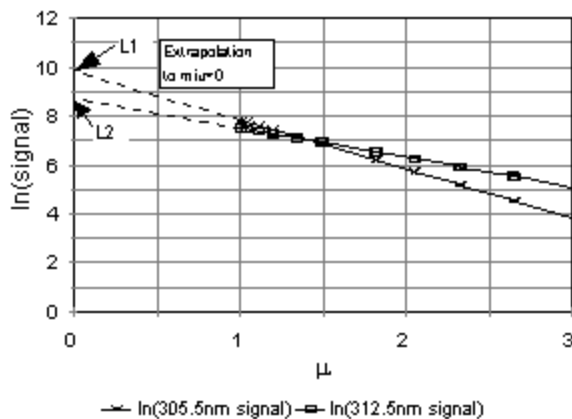

In general, at sea level in the continental United States, $v = 0.99316$, and this value should be used.

The solar zenith angle Z (angle of sun with respect to the zenith) which is the basis for the calculation of μ and m is calculated based on the coordinates of the measurement site and universal time (UT). The algorithm implemented in the MICROTOPS II were tested¹⁰ to an accuracy of $\pm 0.03^\circ$ (max. error) for the entire practical range of latitudes and longitudes, for the time

period of 1996-2006. The error observed comes partially from simplified algorithms and partially from the use of single-precision arithmetic. This error causes negligible effect on ozone calculations. The MICROTOPS II is equipped with a real-time clock and calendar. The coordinates of the location are entered from the keypad or an external computer.

$$\Omega(DU) = \frac{1000 \cdot \left[L_{12} - \ln\left(\frac{I_1}{I_2}\right) - \beta_{12} \cdot m \frac{P}{P_o} \right]}{\alpha_{12} \cdot \mu} \quad (6)$$

where:

$\alpha_{12} = (\alpha_1 - \alpha_2)$, the difference in the ozone coefficients for respective channels 1 and 2

$\beta_{12} = (\beta_1 - \beta_2)$, the difference in the air scattering coefficients for respective channels 1 and 2

$L_{12} = (L_1 - L_2) = \ln(I_{o1}/I_{o2})$, the combined "extraterrestrial constant" (**Error! Reference source not found.**).

L_{12} corresponds to measurement of the incident radiation above the earth's atmosphere (no attenuation from any absorption or scattering process). It is obtained by extrapolating a plot (or doing a regression analysis) of $\ln(I_1/I_2)$ vs. μ (Langley plot). The ozone column thickness is expressed in Dobson units which correspond to milliatm-cm.

Calibration was based on the Langley method which has a long history of application to the Dobson instruments¹¹. A regression analysis is carried out using the most linear portion of Langley plot ($\mu < 1.75$) for each channel and the data is appropriately weighted. The intercept gives the extraterrestrial constant for that channel.

The α 's and β 's for each channel were calculated using a model developed by the TERC project¹². The exponential equation (1) when linearized gives an expression of the form:

$$\ln I = \ln I_o - \alpha\mu - \beta\mu^2 \quad (7)$$

For $m \sim \mu$ it yields a value for $\ln(I_o)$ and a total coefficient value for the remaining terms when subjected to regression analysis. That constant must then be broken down into a term for ozone absorption and a term for the Rayleigh scattering. TERC developed a simple model which assumed that a narrow bandpass filter acts like a filter of a single wavelength. This forces an additional constraint on the coefficients to be determined, because they must both be appropriate for that wavelength. Very helpful is the fact that the α and β change differently with wavelength. To simplify the determination of α and β , the wavelength dependencies of these coefficients were calculated with the following two equations, derived by fitting the ozone cross sections derived by Molina and Molina¹³ and the Rayleigh coefficients of Penndorf¹⁴.

$$\alpha(\lambda) = (2.1349 \times 10^{19}) e^{(-0.14052 \lambda)} \quad (8)$$

$$\beta(\lambda) = (16.407 - 0.085284 \lambda + 0.00011522 \lambda^2) \quad (9)$$

where λ is the wavelength in nm.

Substituting (8) and (9) into (7) one can calculate the slope Δ of the $\ln I$ vs. μ line:

$$\Delta = -1 * ((2.1349 \times 10^{19}) e^{(-0.14052 \lambda)} * \Omega / 1000 + (16.407 - 0.085284 \lambda + 0.00011522 \lambda^2) P/P_o) \quad (10)$$

Table 1 Effective wavelength vs. filter's center wavelength.

| MICROTOPS II Filter's center wavelength [nm] | Typical effective wavelength [nm] |
|--|-----------------------------------|
| 300.0 | 300.8 |
| 305.5 | 306.0 |
| 312.5 | 312.6 |

The effective wavelength λ_o of each channel's interference filter is determined by finding the wavelength at which the slope of the \ln of the measured signal (**Error! Reference source not found.**) matches the theoretical slope Δ . The ozone column for calculation of Δ is taken from a co-located independent instrument, such as Dobson spectrophotometer. Once the λ_o is known, the α and β for each channel can be

calculated from (8) and (9).

For the filters used in MICROTOPS II the effective wavelengths are fraction of a nanometer above the filter's center wavelength (Table 1).

Derivation of water vapor

Water vapor transmission was studied for almost a century¹⁵. The calibration technique used for MICROTOPS was developed by Reagan et.al.¹⁶ and further tested by Michalsky et.al.¹⁷. The water vapor measurement is based on a pair of radiometric measurements in the IR band. The 940nm filter (10nm FWHM) is located in a strong water vapor absorption band, while the 1020nm filter (10nm FWHM) is affected only by aerosol scattering.

For the 940nm channel (indexed with 1) located in the water vapor absorption band the Bouguer-Lambert-Beer law takes the form:

$$\frac{V_1}{V_{01}} = \exp(-\tau_{a1} m - k(um)^b) \quad (11)$$

where V_1 is the ground based radiation at 940nm, V_{01} is the extraterrestrial radiation, τ_{a1} is the aerosol scattering coefficient at 940nm, u is the vertical water vapor column thickness, m is air mass and k and b are constants numerically derived for the filter.

For the 1020nm channel there is negligible water vapor absorption and the equation takes the form:

$$\frac{V_2}{V_{02}} = \exp(-\tau_{a2} m) \quad (12)$$

A radiation transfer model was used to calculate the spectral irradiance around 940nm for standard US atmosphere and various air masses. Subsequently the spectral irradiances from the model were multiplied by the 940nm filter's transmission curve producing the theoretical signal from 940nm detector. Based on (11) a set of k and b parameters was found that matches most closely the simulated results.

The V_{01} for the instrument is found from an extrapolation to air mass zero of the linearized (11):

$$\ln(V_1) + \tau_{a1} m = \ln(V_{01}) - k(um)^b \quad (13)$$

The k and b are already known therefore $\ln(V_{01})$ is the intercept from linear regression of (13) versus m^b . For the water vapor calculation the aerosol scattering coefficient τ_{a1} at 940nm is needed. In MICROTOPS II the aerosol scattering coefficient τ_{a2} at 1020nm is first measured based on (12). The V_{02} is obtained from extrapolation of a Langley plot on a sunny day. From the radiation transfer model a relationship between τ_{a1} and τ_{a2} is found for a standard atmosphere and because of a close proximity of the two bands it is assumed constant for other conditions. For the filters used in MICROTOPS II the relationship is:

$$\tau_{a1} = 1.16 \tau_{a2} \quad (14)$$

The vertical water vapor column is calculated as:

$$u = \left(\frac{\tau_{a1} m (1 - 1.16) - \ln\left(\frac{V_1 V_{02}}{V_2 V_{01}}\right)}{k m^b} \right)^{1/b} \quad (15)$$

Conclusions

The MICROTOPS II is a low-cost hand-held instrument allowing quick and accurate ozone column and water vapor measurements. Tests indicate that the instrument gives reproducible results under various weather and climatic conditions.

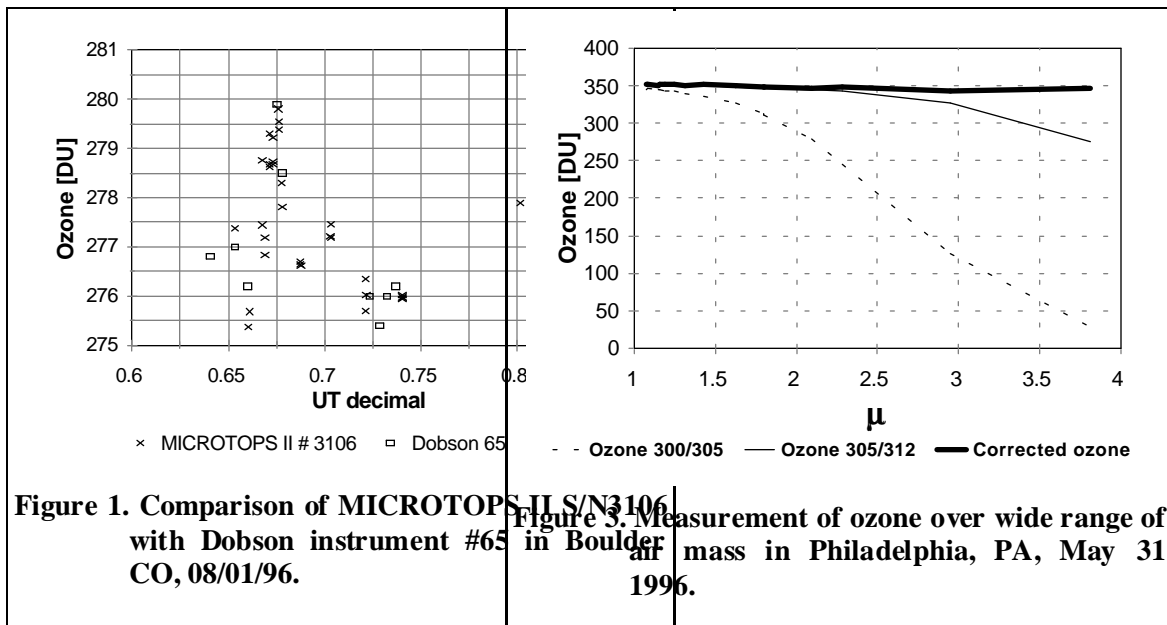

Figure 1. Comparison of MICROTOPS II S/N3106 with Dobson instrument #65 in Boulder CO, 08/01/96. **Figure 3. Measurement of ozone over wide range of air mass in Philadelphia, PA, May 31 1996.**

Figure 1 shows the results of a comparison between Dobson spectrophotometer and MICROTOPS II instrument carried out in Boulder, Colorado, during a demonstration of the Dobson instrument (courtesy NOAA Climate Monitoring and Diagnostic Laboratory). The MICROTOPS II instrument was previously calibrated in Mauna Loa, Hawaii, under substantially different climatic conditions. Comparisons with other instruments are under way and early data indicate good agreement.

The typical agreement between multiple MICROTOPS II instruments is within 1-2%. The repeatability of consecutive ozone measurements is better than 0.5% (**Error! Reference source not found.**).

Measurements through broken clouds or in very hazy conditions show variability of 1-2%.

Similarly to other spectrophotometers¹⁸ the MICROTOPS II exhibits some air mass dependency. This effect is being contributed to out-of-band radiation leaks, scattering of diffuse UV radiation into the instrument's field of view and the effect of the finite bandwidth of the filter itself. Figure 3 shows a series of measurements performed during a sunny day in Philadelphia, PA over a wide range of μ . The ozone calculations based on a single pair, for example 300/305nm or 305/312nm show the air mass dependence effect. With air-mass dependence correction the measurements can be carried out up to an air-mass of 3.8. The quality of calibration depends strongly on weather conditions when the Langley method is used, limiting the number of locations where the calibration can be performed. A calibration based on the spectroradiometric measurements of individual filters is proposed^{5,6} but more experimental data is needed to test its applicability.

References:

1. G. P. Gushchin, Universal'nyi ozonometr. Tr. GI. Geofz. Observ. 141, 83-98 (1963).
2. A. Kh. Khrigian, The Physics of Atmospheric Ozone, 1973. [Translation of Fizika Atmosfernogo Ozone, Gidrometeoizda, Leningrad, by Israel Program for Scientific Translation. 1975. Available from NTIS].
3. R. D. Bojkov, Differences in Dobson spectrophotometers and filter ozonometer measurements of total ozone. J. Appl. Meteor. 8, 362-368 (1969).

4. R. D. Bojkov., N. S. Shpakov and V. T. Zarubaylo, Measurement of total ozone content during the total solar eclipse, 10 July 1972, *Izv. Atmos. Oceanic Phys.* 10, 755-757 (1974).
5. L. G. BolÆshakova, A. L. Osherovich and I. V. Peisakhson, Systematic errors in filter-ozonometry, "Atmospheric Ozone" (*Atmosfernyi Ozon*). Proc. of Ozone Symposium, University Moscow Press, 65-71 (1961).
6. A. L. Osherovich, M. Ya. Rozinskiy and Sh. A. Furman, A comparison between the M-83 standard ozonometer and an ozonometer equipped with narrowband interference filters., *Izv. Atmos. Oceanic Phys.* 5, 593-596 (1969).
7. R. S. Steblova, Notes on International Symposium on Atmospheric Ozone and Certification of Ozonometric Instruments (25 June-9 July 1974, Bielsk, Poland). *Izv. Atmos. Oceanic Phys.* 11, 128-129 (1975).
8. W. A. Matthews, Atmospheric Ozone. Ph.D. thesis, University of Canterbury, New Zealand (1971).
9. W. A. Matthews, R. E. Basher and G. J. Fraser, Filter ozone spectrophotometer. *Pure Appl. Geophys.* 112, 931-938 (1974).
10. R. E. Basher, Stratospheric circulation: A narrowband spectrophotometer for total ozone determination. Ph.D. thesis, University of Canterbury, New Zealand (1975).
11. R. E. Basher and W. A. Matthews, Problems in the use of interference filters for spectrophotometric determination of total ozone *J. Appl. Meteor.* 16, 795-802 (1977).
12. R. E. Basher, The effect of bandwidth on filter instrument total ozone accuracy, *J. Appl. Meteor.* 16, 803-811 (1977).
13. OMIT!!!! NASA Tech News, February, 1996(?). NOTE TO STAN: Can you find the volume and page number(s)?? (Some peer reviewers and editors may object to using a trade publication as a reference.)
14. F. M. Mims III, How to Monitor Ultraviolet Radiation from the Sun, *Scientific American* 263, 106-109 (1992).
15. F. M. Mims III, How to Measure the Ozone Layer, *Sci. Probe* 2, 45-51 (1992).
16. F. M. Mims III and E. R. Mims, Fluctuations in Column Ozone During the Total Solar Eclipse of July 11, 1991, *Geophys. Res. Lett.* 20 367-370 (1993).
17. F. M. Mims III, J. Ladd and R. Blaha, Increased Solar Ultraviolet-B Associated with Record Low Ozone Over Texas, *Geophys. Res. Lett.* 22, 227-230 (1995).
18. F. M. Mims III, Satellite Monitoring Error, *Nature* 361, 505, (1993).
19. R. McPeters and J. F. Gleason, Errors and Ozone Measurement, *Nature* 364, 198 (1993).
20. D. R. Reed, ed., *Spirit of Enterprise: The 1993 Rolex Awards*, Bern: BURI Buri Druck AG, 390-393 (1993).
21. L. E. Flynn, G. J. Labow, R.A. Beach, M. A. Rawlins, and D. E. Flittner, " Estimation of ozone with total ozone portable spectroradiometer instruments. I. Theoretical model and error analysis," *App. Opt.*, 35, 6076-6083 (1996).
22. G. J. Labow, L. E. Flynn, M. A. Rawlins, R.A. Beach, C. A. Simmons, and C. M. Schubert, " Estimation of ozone with total ozone portable spectroradiometer instruments. II. Practical operation and comparisons," *App. Opt.*, 35, 6084-6089 (1996).
23. F. Barnard, A. C. Neuendorffer and G. J. Labow, Unusually Low Ozone Detected Over South-Central U.S., *EOS* 76, 113-115 (1995).

- G.P.Gaushchin et.al. Total ozone measuring instrument used at the USSR station network, in Atmospheric Ozone, edited by: C.S. Zeferos and A. Ghazi, Reidel , Dordrecht (1985)
- 1. A. Smajkiewicz *Filter durability, effect of temperature, humidity, radiation and time*, Barr Associates Inc., private communication
- 2. Forrest M. Mims III., How to Measure the Ozone Layer *Science Probe* 2, 4, 45-51, November 1992.
- 3. Forrest M. Mims III and E. R. Mims, Fluctuations in *Column Ozone During the Total Solar Eclipse of July 11, 1991*, *Geophysical Research Letters*, 20, 5, 367-370, 1993.
- 4. G.J.Labow et.al. *Estimating Ozone with TOPS Instruments - Practical Operation and Comparisons*, *Applied Optics*, Vol. 35, Nr. 30, Oct. 20 1996
- 5. Lawrence E.Flynn *Estimating Ozone with TOPS Instruments Theoretical Model and Error Analysis*, *Applied Optics*, Vol. 35, Nr. 30, Oct. 20 1996
- 6. *Basher and R. W. L. Thomas, Applied Optics, 18, 3361-62 (1979).*
- 7. D. Kohmyr, R.D. Grass and R. K. Leonard, *J. Geophys. Res.*, **94**, 9847-61 (1989).
- 8. D. Kohmyr, *Operations Handbook - Ozone Observations with a Dobson Spectrometer*, WMO, June,1980.
- 9. J.Meeus, *Astronomical algorithms*, 1st ed. , Willmann-Bell 1991
- 10. G. M. B. Dobson and C. W. B. Normand, *Ann. Int. Geophys. Year.*, **5**, 161-191 (1962)
- 11. S. Bannasch, G. Unger, and P. Wagoner, "Preliminary Calibration of TERC Total Ozone Spectrometers," TERC, private communication
- 12. L. T. Molina and M. J. Molina, *J. Geophys. Res.*, **91**, 14501-508 (1986).
- 13. R. Penndorf, *J. Opt. Soc. Amer.*, **47**, 176-82 (1957).
- 14. F.E.Fowle, *The spectroscopic determination of aqueous vapor*, *Astrophys. J.*, 35, 149-162, 1912
- 15. J. Reagan, K.Thome, B.Herman, R.Gall, *Water vapor measurements in the 0.94 micron absorption band: calibration , measurements and data applications*, Proceedings, International Geoscience and Remote Sensing Symposium, Ann Harbor, 1987
- 16. J.J Michalsky, J.C.Liljegren, L.C.Harrison *A comparison of Sun photometer derivations of total column water vapor and ozone to standard measures of the same at the Southern Great Plains Atmospheric Radiation Measurement site*, *JGR*, Vol 100, No. D12, pp.25995-26003, 1995
- 17. M.De gorska, B.Rajewska-Wiech, *Airmass-Dependent Total Ozone Measurement Errors*, Publications of Institute of Geophysics, Polish Academy of Sciences, D-40, 263,(1993)